



VTL Contractor SAFETY guidelines

Revision 11





Document No.VTL-13.WI.017

INTRODUCTION	5
RESPONSIBILITIES, OBLIGATIONS AND RIGHTS OF THE CONTRACTOR.....	6
1. COMPANY POLICY AND KEY RISKS.....	7
1.1. VTL Quality, Environment, Occupational Safety and Occupational Health Policy	7
1.2. Key risks at the terminal and safety requirements	7
1.3. Potential work environment risks at the Terminal	11
1.4. VTL Conduct Policy Framework.....	13
2. GENERAL REQUIREMENTS.....	15
2.1. Conditions for access to the VTL premises for Contractors	15
2.2. Alcohol tests on the premises of VTL	18
2.3. Territory zoning	20
2.4. Requirements for movement of pedestrians, vehicles, bicycles on the premises.....	21
2.5. Maintaining order at the workplace and in personnel premises	27
2.6. Requirements for preparing and equipping workplaces and personnel premises	31
2.7. Occupational health of employees.....	34
2.8. Informing Contractors and Toolbox meetings	35
2.9. Infringements by Contractors	36
2.10. Work supervision.....	37
2.11. Safety signs	38
2.12. Protective equipment.....	39
2.13. Power tools and cable management.....	45
2.14. Locksmith hand tools.....	50
2.15. Fire extinguishers	51
2.16. Chemical substances and their use	55
3. WORK PERMITS	57
3.1. Types of work permits	58
3.2. Drawing up a Permit to Work.....	60
3.3. Workflow of the Permit to work	64
3.4. LockOut/TagOut (LOTO)	65
3.5. Task risk analysis.....	68
3.6. Last minute risk analysis.....	69



CONTENTS

4.	TYPES OF WORK.....	70
4.1.	Earthworks.....	70
4.2.	Work at height.....	78
4.3.	Working on scaffolding.....	84
4.4.	Working on portable ladders.....	88
4.5.	Working with high-pressure devices and painting.....	92
4.6.	Moving cargo.....	95
4.7.	Working with aerial lifts intended for lifting people.....	105
4.8.	Working with special vehicles.....	108
4.9.	Topographic work.....	109
4.10.	Sampling.....	110
4.11.	Removal of asbestos or asbestos-containing materials.....	113
4.12.	Pipelines.....	116
4.13.	Setting up warehouses, building and fastening stacks of materials.....	117
4.14.	Work near water.....	119
4.15.	Work in confined spaces.....	120
4.16.	Introduction of additives.....	126
4.17.	Cleaning of operational equipment.....	129
4.18.	Tank truck filling/discharge.....	131
4.19.	Landscaping and area maintenance.....	133
5.	HOT WORKS.....	134
5.1.	Types of hot works.....	134
5.2.	Requirements for using gas tanks.....	140
6.	DOCUMENTATION.....	143
6.1.	General information.....	143
6.2.	'Work execution plan' (WEP).....	143
7.	ENVIRONMENTAL PROTECTION.....	145
7.1.	General requirements.....	145
7.2.	Waste management.....	145
7.3.	Protecting greenery.....	147
8.	EMERGENCIES.....	148
8.1.	How to act in an emergency and during evacuation drills.....	148
8.2.	Using a Dräger PARAT 7530 escape hood.....	151
8.3.	First aid.....	153
9.	CONTACT DETAILS OF PERSONS IN CHARGE.....	155



Related documents:

VTL-13.FM.035 “Minutes of meeting with contractors”

VTL-13.FN.012 “Permit to Work”

VTL-13.FN.029 “Permit to Work: hot works”

VTL-13.FN.028 “Permit for earthworks”

VTL-13.FN.002 “Permit for work in confined spaces”

VTL-13.FN.030 “Permit to Work on electrical installations”

VTL-13.FN.036 “Work equipment inspection protocol”

VTL-16.FM.010 “Guidelines for development of work project/plan”

VTL-16.FM.004 “Task risk analysis”

VTL-13.WI.209: 7 “Cargo handling plan”

VTL-13.FM.038 “Acknowledgment of receipt of VTL Contractor Safety Guidelines”



INTRODUCTION

SIA Vitol Terminal Latvia (VTL) is the largest and most technologically advanced oil and oil product transshipment facility in the Baltic states, operating for more than 60 years in the ice-free port of Ventspils. The VTL brand is not just a logo or a name. It is a way of thinking shared by our customers, suppliers, shareholders and employees.

VTL supports open, fair and honest competition between operators and suppliers. Selection of contractors and suppliers is based on their qualifications and skills required to perform the work or to provide the services, the commercial competitiveness of their tenders, as well as their reputation and credibility.

The company places great emphasis on safety, concordance and environmental protection and requires compliance with these requirements not only from its employees, but also from all contractors and their respective employees involved in the development and modernisation of the terminal.

These guidelines are intended as a helpful tool for the Contractor to gain a better understanding of the working safety requirements on site. The guidelines not only set out the requirements, but also provide visual examples of best practice and the most common mistakes.

The guidelines are available in three languages: Latvian, Russian, English. In the case of discrepancies, the Latvian language version shall prevail.

The annexes referred to in the guidelines are issued to the contractor after the commencement of contractual obligations at VTL.

The company has implemented and operates in accordance with the following standards:



In acknowledgment of the company’s policy and steadfast commitment to safety, environmental protection, and sustainability, VTL has been honored with numerous prestigious awards and recognitions. These include the designation as a “Fair Remuneration Employer 2024,” the receipt of the “Golden Helmet” award for excellence in occupational health and safety practices, recognition over consecutive years as the terminal with the highest cargo turnover in the regional port, and the attainment of “Family-Friendly Workplace” status. Additionally, the company’s implemented initiatives have been repeatedly highlighted as exemplary practices among Latvian businesses.





KEY RISKS AT THE TERMINAL AND THE ROLE AND POLICY OF SAFETY

RESPONSIBILITIES, OBLIGATIONS AND RIGHTS OF THE CONTRACTOR

1. The Contractor must comply with the safety requirements set out in these guidelines throughout the entire period of performance of work in order to ensure the sustainability, safety and well-being of all employees working on site and the environment.
2. The Contractor is responsible for ensuring that their employees and those of the subcontractors involved are familiar with the contents of the VTL Contractor Safety Guidelines.
3. The responsible employees and workers of the Contractor are responsible for complying with and ensuring the specified requirements.
4. If, due to justified reasons, the Contractor is unable to comply with any of the requirements specified in the guidelines, the Contractor has the right to agree in writing with the EHS manager of VTL on deviations from the specified requirements.
5. Prior to the commencement of the works, the Contractor shall submit the HSEQ Department of VTL a **Declaration** issued after the commencement of the contractual obligations that the Contractor's employees have been acquainted with the contents of these guidelines.



KEY RISKS AT THE TERMINAL AND THE ROLE AND POLICY OF SAFETY

1. COMPANY POLICY AND KEY RISKS

1.1. VTL Quality, Environment, Occupational Safety and Occupational Health Policy

1.1.1. Vision – We are the most valuable and reliable cooperation partner for each of our customers.

1.1.2. Mission – We never stop seeking the best way to add value for our customer. We love the challenges that lie ahead. We believe that everything we do is important and contributes to the success of the terminal. We are proud of what we do and we see the terminal as part of ourselves. We are aware of our role in ecology, in our community and in the environment. We are investing in future generations.

1.1.3. Key goals:

1.1.3.1. Seeking business opportunities;

1.1.3.2. Flexibility and adaptation to current and future business needs;

1.1.3.3. Continuously improving increasing efficiency and productivity;

1.1.3.4. Health and Safety and Environmental Protection is priority No. 1;

1.1.3.5. Promoting sustainability;

1.1.3.6. Reducing emissions;

1.1.3.7. Cooperating with and supporting the local community;

1.1.3.8. Compliance with the regulatory and other requirements;

1.1.3.9. Professional business management;

1.1.3.10. Working according to the Company values.

1.2. Key risks at the terminal and safety requirements

1.2.1. Vitol Terminal Latvia is an explosion- and fire-hazardous facility with complex infrastructure and a large amount of various extremely flammable, highly flammable and flammable liquids stored.

1.2.2. The potential environmental impact resulting from the operation of the terminal is related to possible non-compliances and emergencies – large-scale spills of oil products, fires, inadequate condition of the equipment. Under normal conditions, the environmental impact is related to the electricity consumption and odours arising during the production processes at the terminal, such as filling tanks.

1.2.3. The terminal has very high requirements for explosion safety, fire safety, occupational and environmental protection that equally apply to the employees and the equipment and machinery used.



KEY RISKS AT THE TERMINAL AND THE ROLE AND POLICY OF SAFETY

1.2.4. The company has implemented the following “Life-Saving Regulations”, any violation of which is classified as an accident:

MAIN PROVISIONS		Get a permit before entering a CONFINED SPACE		Protect yourself against falls when working at height		Use a safety belt	
		Where required, work with a valid permit to work		Do not walk or stand under lifted loads		Observe the lockout/tagout rules for machinery and the production process	
	ADDITIONAL PROVISIONS		Keep a safe distance from moving equipment		No alcohol or drugs at work or while driving		Obtain permission before starting excavation work
			Wear a life jacket while being within 1 a distance of metre from the water		Do not smoke outside designated smoking areas		Follow the Cargo handling plan

KEEP YOUR DISTANCE



DO NOT SHAKE HANDS



WASH YOUR HANDS REGULARLY



FEVER/COUGH = STAY AT HOME





KEY RISKS AT THE TERMINAL AND THE ROLE AND POLICY OF SAFETY

1.2.5. The safety and occupational health of every employee working on the premises of the company matters to the company. To ensure this, the company inspects the work sites and personnel premises of the Contractors on a regular basis and controls compliance with the occupational health and safety requirements applicable at the terminal.

1.2.6. All incidents that have occurred, including accidents involving the Contractor's employees are investigated, seeking to determine the possible causes of the accident (direct and indirect), taking measures to prevent similar incidents, as well as controlling the implementation and execution of such measures. **The Contractor has the obligation to immediately report any incidents and accidents that have occurred on the premises of VTL to the responsible employee of VTL.**

1.2.7. The Contractor's employee may report an accident both openly and anonymously, using the VTL electronic tool "Gurufield". A link to the electronic system is available here: <https://vtl.gurufield.com/>.

1.2.8. The terminal has undergone an industrial risk assessment within which accident development scenarios related to the principal activity of the terminal have been analysed. The assessment calculations at the facility show that the production processes implemented by the terminal, as well as the results of individual risk modelling as part of the risk assessment characterising the total, cumulative risk posed by the facility to the residents in its vicinity, do not exceed acceptable individual risk limits – 1×10^6 . The consequences of potential accidents do not extend outside the protection zone of the company. Direct exposure of the residents in the vicinity is not expected. Detailed information on the results of the risk assessment of the facility and exposure to the consequences of accidents can be obtained in the Safety Report of the facility available at the office of Vitol Terminal Latvia at 75 Talsu Street (Ventspils). It is freely available to anyone interested on business days, from 10:00 to 16:00, by prior appointment, calling +371 63666334.

1.2.9. All facilities of the Terminal are equipped with automatic fire detection and alarm devices, tanks are equipped with automatic fire extinguishing and cooling systems.

1.2.10. All explosion-hazardous areas are divided into zones and a risk assessment of the potentially explosive environment has been carried out.

1.2.11. Buildings and rooms where explosion hazards may occur are equipped with air composition control and warning devices.

1.2.12. Only explosion-proof tools and equipment are used when working in potentially explosive environment. All equipment and devices are regularly inspected according to schedule.

1.2.13. In order to duly comply with the applicable safety requirements, the following is **strictly prohibited at the Terminal**:

1.2.13.1. Smoking and using an open flame, except for in appropriately equipped and designated areas;



KEY RISKS AT THE TERMINAL AND THE ROLE AND POLICY OF SAFETY



1.2.13.2. Using mobile phones (also applies to carrying them in the process zone in a switched-on state), cameras, other consumer electronics in potentially explosive areas, unless the device is not in an explosion-proof version and is not intended for use in zone “0”, “1” or “2”;



1.2.13.3. mobile phones that are not explosion-proof may be used in the green zone or process zones, except for potentially explosive zones, in vehicles with closed doors and windows;



1.2.13.4. using tools that generate sparks in potentially explosive areas;

1.2.13.5. using non-explosion-proof electrical devices in potentially explosive areas;

1.2.13.6. using work clothing that can generate sparks and static electricity;

1.2.13.7. touching objects that may be explosive, chemically hazardous or of unknown origin.

1.2.14. **Connection to running equipment/technologies and equipment protection measures** – connection to the process lines of the terminal is performed by both the Contractor’s employees and VTL personnel. Any interaction with the systems built by VTL shall only take place after approval by VTL project managers.



KEY RISKS AT THE TERMINAL AND THE ROLE AND POLICY OF SAFETY

1.2.15. Any employee who performs their job duties at VTL is responsible for their own safety and health at work, as well as for the safety and health of persons who are or may be affected by their behaviour and actions or omissions.

1.3. Potential work environment risks at the Terminal

1.3.1. Physical risks.

1.3.1.1. **Noise**, such as while moving around the area, along process pumping stations, reservoirs undergoing repairs;

1.3.1.2. **Lighting**, such as while moving around the area at night;

1.3.1.3. **Microclimate**, such as while working in the buildings of the Terminal;

1.3.1.4. **Order**, such as while moving around the area;

1.3.1.5. **Outdoor work**, walking around the terminal area and buildings, performing work duties in tank parks, on tanks, on gantries, in process structures (pumping stations, manifolds, etc.), during visits to the buildings.

1.3.2. **Ergonomic risks**. Remaining in a forced position, such as while working inside tanks with a pontoon; moving loads, such as while repairing different operational equipment.

1.3.3. **Psychological and emotional risks**. Performance of work duties in potentially flammable and explosive facilities, night work, work in solitude;

1.3.4. Dust sprays.

1.3.4.1. **Silicate-containing dust**, such as being present in the area where the tanks are sandblasted;

1.3.4.2. **Abrasive dust**, such as while remaining inside tanks during repairs.

1.3.5. Chemical risks.

1.3.5.1. **Aliphatic and aromatic hydrocarbons**, such as while cleaning tanks, taking samples from tanks or rail tank cars, performing maintenance and repairs of the equipment installed on the tanks;

1.3.5.2. **Hydrogen sulphide**, such as when taking samples from tanks or rail tank cars, cleaning tanks, performing maintenance and repairs of the equipment installed on the tanks;

1.3.5.3. **Methanol, ethanol, various ethers, acetones**, such as while taking samples from tanks or rail tank cars, cleaning tanks, performing maintenance and repairs of the equipment installed on the tanks;

1.3.5.4. **Mercaptans**, such as while taking samples from tanks or rail tank cars, cleaning tanks, performing maintenance and repairs of the equipment installed on the tanks;

1.3.5.5. **Liquefied petroleum gases**, such as butane, isobutane, pentane, isopentane, butane-butylene fraction, while taking samples or cleaning tanks;

1.3.5.6. **Asphyxiating gases**, such as nitrogen while performing equipment maintenance;

1.3.5.7. **Welding aerosols**, such as while repairing the tanks;

1.3.5.8. **Toxic substances** such as phenol, formaldehyde while cleaning tanks.

1.3.6. **Biological risks**. For example, tick-borne diseases, various insect bites.

1.3.7. **Carcinogenic chemical factors**. Such as **benzene** while taking samples or cleaning tanks, or performing maintenance and repairs of the equipment installed on the tanks.



KEY RISKS AT THE TERMINAL AND THE ROLE AND POLICY OF SAFETY

1.3.8. Injury risk factors.

1.3.8.1. **Machinery and equipment**, such as area gates, mechanised equipment, vehicles;

1.3.8.2. **Technical equipment**, such as lifts, hazardous equipment (tanks), pressure vessels, discharge platforms, miscellaneous machinery;

1.3.8.3. **Work at height**, such as on the roofs of tanks (including domed ones), on rail tank cars, lighting masts, etc.;

1.3.8.4. **Tripping and slipping**, such as while moving around the area, climbing/descending tanks, etc.;

1.3.8.5. **Internal vehicles and traffic**, such as while moving along the road pavement within the area or driving a vehicle without complying with road traffic regulations and VTL regulations;

1.3.8.6. **Work on or near road pavement**, including railway tracks, such as work duties while on elevated rail structures;

1.3.8.7. **Live electrical installations**, such as while working on electrical switchgear;

1.3.8.8. **Work in confined spaces**, such as work in trenches, manholes, tanks, etc.;

1.3.8.9. **Fires, explosions**, such as while repairing process equipment (tanks, pipelines) or while performing work in an explosive environment;

1.3.8.10. **Falling objects**, such as being present in areas where work at height with work using lifting equipment is taking place, working in a hoist basket, working in manholes;

1.3.8.11. **Risk of drowning**, such as while working on piers in the coastal berth area;

1.3.8.12. **Insufficient knowledge**, such as while performing work duties, applying work methods that differ from VTL practices or employee safety culture that differs from that of VTL.



KEY RISKS AT THE TERMINAL AND THE ROLE AND POLICY OF SAFETY

1.4. VTL Conduct Policy Framework

We believe that a consistent and long lasting development may only be achieved by recognising the interests of all stakeholders involved. To achieve that, we take into account the interests of our customers, employees, shareholders, investors and suppliers, as well as the environment and local communities in which we operate. We encourage and support a commitment to achieving the best in all paths and in all areas. We encourage others in our business community, the customers, service providers and partners of all kinds, to share our commitment to acting responsibly in all aspects. We seek to do business with those who agree with these principles and include a responsibility and compliance factor in their decisions regarding their activities. Any breach of the VTL Compliance Policy and related controls is taken seriously.

1.4.1. Ethical business practice

We always act according to the highest standards of conduct, being honest and fair to our customers, business partners and stakeholders. Dealing with customers, business partners and stakeholders we behave ethically and in good faith.

1.4.2. Protection of confidential data

The continued success of our business and the maintenance of our reputation depend on the commitment of our employees to uphold confidentiality. We respect the confidentiality of the information we receive and disclose it responsibly and only to authorized or legally justified persons.

1.4.3. Compliance with the current laws and regulations

We keep up to date with relevant laws and regulations and comply with them in practice. When in doubt, we consult our lawyers or the VTL compliance team.

1.4.4. Anti-bribery and corruption

We provide a variety of resources, including training, to maintain a deep understanding of our anti-bribery and anti-corruption policies and ensure compliance.

1.4.5. Conflicts of interest

We avoid conflicts of interest and seek to mitigate them where they exist. We are familiar with and comply with VTL policies and procedures.

1.4.6. Relations with government officials

We engage in honest and transparent with all relevant national, local, and other regulatory authorities, striving to facilitate the efficiency of the markets in which we operate.

1.4.7. Political activities

We do not utilise the means and resources of the company to support political parties, organisations, campaigns or other events.



KEY RISKS AT THE TERMINAL AND THE ROLE AND POLICY OF SAFETY

1.4.8. **Relations with business partners and partners**

We ensure that research and control procedures are followed consistently. We value confidentiality and respect the information we collect.

1.4.9. **Responsible actions**

We are familiar with the conceptual framework of sustainable action and approach. We assess the risks associated with any initiative we are involved in and therefore implement our decisions in accordance with the sustainability guidelines and beliefs.

1.4.10. **Preserving human rights**

We take human rights considerations into account and act accordingly. Any doubts, questions or concerns raised are addressed in collaboration with senior management.



CONDITIONS FOR ACCESS TO THE VNT PREMISES FOR CONTRACTORS

2. GENERAL REQUIREMENTS

2.1. Conditions for access to the VTL premises for Contractors

- 2.1.1. The premises of Vitol Terminal Latvia have a strict access control procedure, as well as a procedure for ensuring the movement and control of persons, vehicles and material assets.
- 2.1.2. Movement of persons and removal of material assets from the premises of VTL is only allowed through access points. In order to obtain access cards to the premises of Vitol Terminal Latvia (hereinafter – VTL), it is necessary to submit an application for the preparation of access cards in a timely manner (no later than five working days in advance). The application must contain the full name and personal identification code of the persons, make and licence plate number of the vehicle. The application for the issuance of access cards shall be approved by the head of VTL HSEQ Division, after which the persons and vehicles are background-checked by the State Border Guard under the Ministry of the Interior.
- 2.1.3. The employees of VTL Contractors receive:
 - 2.1.3.1. one-time access cards;
 - 2.1.3.2. permanent access cards.
- 2.1.4. It is forbidden to hand over the access card to third parties.
- 2.1.5. Any access card is valid only for the person it has been issued to.
- 2.1.6. VTL access and control system operates with biometry data control and vehicle license plate automatic recognition system.
- 2.1.7. Vitol Terminal Latvia issues the access cards free of charge, however, if a card is lost, a fine of **EUR 30.00** per card shall be due.
- 2.1.8. Prior to receiving the access cards, the Contractor's employees must be instructed on the safety requirements while present and working on the VTL premises, watch the safety video and successfully pass the knowledge test that verifies that the Contractor's employee is familiar with the safety requirements applicable at VTL.



CONDITIONS FOR ACCESS TO THE VNT PREMISES FOR CONTRACTORS

- 2.1.9. In the case of successful acquisition of knowledge, the employee receives a safety card for successful completion of VTL labour safety training and an access card is issued or activated.
- 2.1.10. In the case of registering a violation of VTL safety requirements by the Contractor the Contractor's employee's access card may be revoked and the employee is dispatched to undergo additional training. The violation is recorded in the VTL report system (*Gurufield*).
- 2.1.11. Only an authorised employee of the company (**company management, HSEQ specialists, safety coordinators, project managers**) may revoke the safety card.
- 2.1.12. Upon committing three violations the employee's access card to the VTL premises is revoked. In case a violation of life-saving requirements or a serious hazard to the environment or the property of the Terminal is recorded, the authorised VTL employee may revoke the Contractor's employee's access card without prior notice.
- 2.1.13. The Contractor's access card shall be reactivated only after the employee has received a repeated briefing and successfully passed a knowledge test, but not earlier than the second working day from the date of cancellation of the access card, giving the employee the opportunity to learn the training material.
- 2.1.14. The Contractor's employees conduct safety briefings remotely. In order to implement this, the Contractor shall provide the Access Control Inspector with the employees' work or personal email address when requesting access cards. Links, which, when activated, allow the employee to independently learn the safety requirements of the VTL and also pass a knowledge test, are sent to this email address. The results of the test are automatically sent to the Access Control Inspector and the employee.
- 2.1.15. If the employee attends the safety briefing remotely, the Access Control Inspector is entitled to check the employee's knowledge by asking control questions on the safety requirements of VTL at the time the access card is issued or activated.
- 2.1.16. **Safety briefing** of Contractors' employees can take place on weekdays from **9:00 to 16:00**.
- 2.1.17. If the Contractor's employee attends the safety briefing at VTL and fails to pass the test with the first attempt, the test can be repeated no earlier than on the next working day.
- 2.1.18. Employees of Contractors who repeatedly violate the same safety requirements while present and working on the premises of VTL shall have to repeat the briefing on the specific subject. The briefing is conducted by the Contractor's labour safety officer. In this case the employee's access card is activated only after taking an oral knowledge test conducted by a VTL safety coordinator and project manager.
- 2.1.19. The requirements set forth in Paragraph 2.1.8. do not apply to visitors to the premises of VTL who:
- 2.1.19.1. deliver mail, letters, documents;
- 2.1.19.2. visit for an interview, meeting, product presentation;
- 2.1.19.3. are accompanied by a VTL employee during the visit.
- 2.1.20. All employees who enter or leave the premises of the company are required to present the contents of the belongings they carry if requested to do so by the security guard of the company.
- 2.1.21. Removing material assets from the premises of VTL is only allowed with duly executed delivery notes/access cards.



CONDITIONS FOR ACCESS TO THE VNT PREMISES FOR CONTRACTORS

2.1.22. In the case of removing material assets from the premises of VTL, asset transfer forms must be prepared. The asset transfer forms shall be approved by the duly authorised staff of VTL (heads of divisions, heads of departments).

Nr.p.k.	Materiāls vērtības nosaukums	Mērvienība	Daudzums	Pāņemšanas datums	Apgriezts (apzīmē paraksts)

- 2.1.23. Before the commencement of work (preparatory work), the Contractor shall verify any high-risk tools, devices, machinery and equipment, as well as fire extinguishing equipment used for work tasks. It is forbidden to use unverified equipment, tools or devices for the performance of work. The verification of a device, tool or equipment is attested by a statement compiled by a competent specialist or the user himself. A list of devices, tools, equipment to be verified by a competent specialist or service organisation is represented in Paragraphs 2.13 and 2.14 of these guidelines.
- 2.1.24. If the competencies and conduct of the employees that the Contractor plans to involve in the performance of work do not comply with the relevant requirements, VTL has the right to deny these employees access to the premises of the terminal or the facility at any time, at the Contractor's expense.
- 2.1.25. Damaged, lost, stolen or otherwise unusable access passes must be reported to the VTL Pass Inspector by calling **6366 6309** and explaining the circumstances of the loss of the access pass.
- 2.1.26. Upon the expiry of all access passes issued by VTL, as well as in other cases when the issued access pass is no longer required by the person or the person is barred from accessing the premises of VTL, the access pass must be immediately handed over to VTL access pass inspector. The user of the access pass is responsible for handing it over.



ALCOHOL TESTS ON THE PREMISES OF VNT

2.2. Alcohol tests on the premises of VTL



ALCOHOLIC AND NARCOTIC SUBSTANCES ARE PROHIBITED



Working under the influence of alcohol, certain medications, drugs or other substances reduces the ability to work safely.

- Notify your direct superior or the responsible employee if you are taking medications that may affect your ability to work.
- If you have any doubts about the use of medication and their effects, your direct superior may seek the advice of a qualified doctor.
- Think ahead. Stimulants accumulate in your body for a long time and affect your ability to work or drive vehicles. While at work, you must be free from the effects of any substances on your body.
- Take action if you suspect that someone is under the influence of alcohol or drugs during work. This person is dangerous and endangers not only themselves, but also others. Report it to the direct superior.

2.2.1. It is not allowed to bring alcoholic beverages, narcotic or toxic substances onto the premises of Vitol Terminal Latvia, consume them or be under the influence/intoxication of such substances.

2.2.2. Employees of the Contractor on the premises of Vitol Terminal Latvia and any other persons on the premises are bound by the “Zero Blood Alcohol” policy. Failure to comply with this provision will be considered a breach of the Company procedures, which is the basis for revocation of the access pass of the Contractor's employee, or a possible termination of the contractual relationship with the Contractor and imposing a fine on the Contractor.

2.2.3. Breathalyser testing prior to entering VTL premises:

2.2.3.1. All employees and visitors are required to undergo an breathalyser test using an automatic (stationary) calibrated breathalyser before entering VTL premises.



2.2.3.2. Employees who refuse to undergo the breathalyser test will not be granted access to VTL premises.

2.2.3.3. If the breathalyser test indicates the presence of alcohol, the employee will be denied entry to VTL



ALCOHOL TESTS ON THE PREMISES OF VNT

premises, and the respective employer of the individual will be notified.

2.2.3.4. If, during the calendar year, an employee is found to have alcohol present in their breath during a subsequent test, their access pass will be blocked. The direct employer of the individual will be informed accordingly. The access pass can only be reactivated upon receipt of written authorisation (including via email) from the HSEQ Manager.

2.2.4. The authorised representative of Vitol Terminal Latvia has the right to conduct breathalyser tests and saliva drug tests on any Contractor employee at any time and location within the company premises. A certified breathalyser (“police” type breathalyser) for alcohol testing, and disposable drug testing kits are used.



2.2.5. If the Contractor's employee refuses or avoids the testing of exhalation alcohol concentration or presence of narcotic substances in saliva, it is considered a significant violation of VTL procedures, and the employee's access pass to the premises of Vitol Terminal Latvia is revoked, as well as a fine may be imposed on the Contractor.

2.2.6. If an employee's breath is found to contain concentration of alcohol, a report is prepared with the recorded values, the access pass is revoked and the employee is immediately escorted off the premises.

2.2.7. If an employee's saliva sample is found to contain narcotic substances, a report is prepared with the recorded values, the access pass is revoked and the employee is immediately handed over to the State Police.



2.3. Territory zoning

2.3.1. The entire premises of the company are divided into two zones:

2.3.1.1. **The green zone** – here an employee can freely move in civilian clothing in vehicles or on foot, in compliance with traffic regulations;

2.3.1.2. Production process zone:

- the employee must wear the specified personal protective equipment (**antistatic work clothing, safety helmet, goggles, antistatic work shoes, protective gloves**);
- the requirements for work clothing may be relieved (regarding antistatic work clothing), assessing the specifics of each work task and the risks associated with it.
- it is forbidden to use (keep switched on) electronic devices, including phones that are not explosion-proof;
- it is forbidden to photograph and film if a Permit to work has not been executed, and
- there are also traffic restrictions.

2.3.2. The zoning of the terminal (the “green” zone, the “process” zone) is explained to the employees during the annual security briefing.



REQUIREMENTS FOR MOVEMENT OF PEDESTRIANS, VEHICLES, BICYCLES ON THE PREMISES

2.4. Requirements for movement of pedestrians, vehicles, bicycles on the premises



ALWAYS USE A SEATBELT



- Check that the seatbelt is in working order.
- Use a seatbelt in all vehicles equipped with it, including a rental vehicle, taxi, bus, crane, truck, etc.
- Before setting off, check to make sure that all passengers of the vehicle are wearing their seatbelt.
- Do not unfasten the seatbelt during movement.
- Regardless of whether you are the driver or a passenger – make sure that everyone's seatbelt is fastened.



KEEP A SAFE DISTANCE FROM MOVING EQUIPMENT



Make sure that you are outside the working zone of moving or rotating equipment while working:

- Do not cross safety barriers. They may indicate that the equipment is still in operation.
- A valid work permit has been issued.
- Make sure that the driver or equipment operator maintains eye contact with you.
- Be noticeable. When working near equipment or in its area of operation, wear high-visibility clothing.
- Before entering a hazardous or confined area, confirm with the responsible employee that it is safe to access it.

- 2.4.1. The road traffic regulations of the Republic of Latvia apply on the premises of the company.
- 2.4.2. Pedestrians are allowed to move on pedestrian paths and pavements. If it is required to move on the roadway, exercise caution and move in the opposite direction to traffic. Note and comply with road traffic regulations and the climate conditions on the premises and outside them.
- 2.4.3. Only cross pipelines and bunding at designated locations.
- 2.4.4. Do not climb on or under pipelines.
- 2.4.5. Do not enter trenches, tanks or manholes if the employee is not trained and no Permit to Work has been issued for the performance of work.
- 2.4.6. Do not touch or lean on equipment fences and enclosures, except for special guardrails.
- 2.4.7. During the dark hours of the day, employees must wear clothing with reflective elements or use a flashlight while in unlit areas.



REQUIREMENTS FOR MOVEMENT OF PEDESTRIANS, VEHICLES, BICYCLES ON THE PREMISES

- 2.4.8. While in an area where special equipment (crane, tractor, hoist truck, hydraulic manipulator or other large equipment) is operating, observe a distance of at least 5 m from its moving parts, as well as pay attention to the warning signals of special equipment.
- 2.4.9. While moving on stairs, the employee must maintain three points of contact simultaneously – one hand and two feet or two hands and one foot.



- 2.4.10. The applicable speed limit on the premises of the company is **30 km/h**.
- 2.4.11. While moving in the green area, the employee is allowed to use audio headphones, provided that only one headphone is used to be able to hear ambient sounds and other warning signals.
- 2.4.12. The driver of a vehicle must be in possession of a valid driving licence for the appropriate category and a medical certificate.
- 2.4.13. Movement on the premises is only allowed using a vehicle in good technical order, equipped with a **suitable fire extinguisher** with a volume specified in the fire safety and road traffic regulations, a medical first aid kit, a reflective vest and an emergency triangle.
- 2.4.14. When setting off, the driver must make sure that the movement of the vehicle will not injure the surrounding employees, that there are no obstacles in the way that could injure other employees or damage the vehicle; if necessary – sound the horn.
- 2.4.15. When driving a vehicle **equipped with seat belts, THE SEAT BELTS MUST BE FASTENED** and the driver must not set off before **all passengers have fastened their seatbelts**, including those sitting in the rear seat.
- 2.4.16. It is prohibited to carry passengers in a vehicle not intended for it, for example, in a truck bed, cargo compartment or similar.
- 2.4.17. If, regardless of the circumstances, a contractor's employee is required to be in the vicinity of the VTL oil vapour collection facility **within a 3 m radius**, the **employee must carry an individual gas analyser** (explosion hazard (LEL) and hydrogen sulphide (H₂S)).



REQUIREMENTS FOR MOVEMENT OF PEDESTRIANS, VEHICLES, BICYCLES ON THE PREMISES

- 2.4.18. Do not exceed the speed limit while driving the vehicle. When choosing the speed take into account:
- 2.4.18.1. the intensity of traffic on the road, the specifics, layout and condition of the vehicle and cargo;
 - 2.4.18.2. road and meteorological (climate) conditions;
 - 2.4.18.3. depending on the driving speed, choice of a distance that permits avoiding a collision when the vehicle in front brakes, and also choice of a safe interval.
- 2.4.19. It is prohibited to drive a vehicle under the influence of alcohol, drugs, psychotropics or other intoxicating substances.
- 2.4.20. Passengers are not allowed to get in or out of the vehicle while the vehicle is in motion.
- 2.4.21. When driving a vehicle or riding a bicycle, it is permitted to use a mobile phone **if a mobile phone headset or a stationary hands-free system is used**, or if the vehicle is **stopped** without endangering other road users.
- 2.4.22. While working in an accident area (polluted area), it is only allowed to enter the area after determining the air composition and only with the permission of the responsible emergency response manager.
- 2.4.23. Frozen systems and safety devices may only be thawed with hot water or hot air.
- 2.4.24. Vehicles can be left in specially equipped parking areas on the premises of the company. If a vehicle is left outside the designated parking areas of the company, it must be unlocked and with the keys in the ignition (if equipped).



- 2.4.25. Vehicles must be parked in designated parking areas within VTL premises (near the Administrative building, opposite the Electrical workshop building, adjacent to the Repair Workshop, near the Fire Depot, and by the Control room of Tank pit No.1) and in pockets located along roadways. Parking vehicles outside of these designated areas is permitted temporarily, for example, for loading or unloading of cargo.
- 2.4.26. Whenever possible, move vehicles forward when navigating through the terminal area, avoiding driving in reverse.
- 2.4.27. Exercise extreme caution when positioning vehicles on the premises, ensuring there are no



REQUIREMENTS FOR MOVEMENT OF PEDESTRIANS, VEHICLES, BICYCLES ON THE PREMISES

obstacles in the intended direction of travel, such as fire hydrants, road bollards, valves, etc., before starting any movement.

- 2.4.28. When parking the vehicle in a parking area on the premises of VTL, the vehicle must be parked facing the direction of departure (forward).



- 2.4.29. A bicycle must be equipped with reflectors, at least at the front and rear, and/or lights, as well as a chain guard. If the bicycle is not equipped with reflectors or lights, the cyclist must wear a reflective vest or clothing with reflective elements during the hours of darkness or in difficult visibility conditions (fog, mist, snowfall, etc.).

- 2.4.30. Unified principles of employee conduct (safety culture) cannot be established. Therefore, in each specific situation, the employee must move and act carefully to avoid endangering their own and others' health and lives. Safe practices should be chosen for everyday activities both at work and outside of it, as well as during work operations.

- 2.4.31. **The following is not allowed** on the premises of the company:

- 2.4.31.1. Performing vehicle repairs or maintenance. Vehicle repairs are only permitted:

- if the vehicle cannot be moved to a repair location;
- if the repairs have been approved by the VTL supervisor and the FRSS;
- if all necessary measures have been taken to prevent environmental pollution.

- 2.4.31.2. Parking the vehicle near process equipment or fire hydrants.



REQUIREMENTS FOR MOVEMENT OF PEDESTRIANS, VEHICLES, BICYCLES ON THE PREMISES



2.4.32. All employees of the Contractors must have an employee's certificate, which the employee must carry and, if necessary, present to the staff of VTL or external institutions. The employee's certificate must contain the following information about the employee:

- company name;
- name, surname, photograph;
- employment contract No.;
- signature and stamp of the authorised person of the company.



2.4.33. The Contractor may also have a list of all employees. In such case, the list should contain the information referred to in Paragraph 2.4.32.



REQUIREMENTS FOR MOVEMENT OF PEDESTRIANS, VEHICLES, BICYCLES ON THE PREMISES

2.4.34. While on the premises of VTL, the employee must always carry the issued ID (access) card.





MAINTAINING ORDER AT THE WORKPLACE AND IN PERSONNEL PREMISES

2.5. Maintaining order at the workplace and in personnel premises

- 2.5.1. Each employee has the obligation to maintain a clean and tidy work environment around them – at the workplace, in the personnel premises, in the material and tool storage areas.
- 2.5.2. The Contractor is responsible for constantly maintaining order at the site where the work is taking place, the surrounding area and the Contractor's premises.
- 2.5.3. The construction site, the surrounding area and the Contractor's premises must be maintained in order. The Contractor is required to remove construction debris and industrial waste from the premises of VTL on a weekly basis.
- 2.5.4. The contractor must clean their personnel premises once a week.
- 2.5.5. Stored materials should be arranged in stacks that cannot tip over or endanger workers.



Improper placement and storage of materials



MAINTAINING ORDER AT THE WORKPLACE AND IN PERSONNEL PREMISES

- 2.5.6. At the end of each working day, arrange the work tools and place them in the storage provided, collect the waste generated during work and place it in appropriate waste containers: municipal waste separately, hazardous waste separately, construction waste separately.
- 2.5.7. Any objects (tools, equipment, materials, etc.) that are in the way of employees and may pose a danger to the employees must be moved to another location or other safety measures must be taken to ensure the safety of the employees.



Sharp objects at eye level



Securing sharp objects against accidentally injuring the employee

- 2.5.8. If unintended movement is possible in stacks, additional safety measures must be taken to prevent this.



Materials secured using special wedges to prevent them from rolling onto the pedestrian paths. Pedestrian path separated by cones (serving as a barrier)



MAINTAINING ORDER AT THE WORKPLACE AND IN PERSONNEL PREMISES



Materials grouped by type and securely fastened against movement

2.5.9. Place the waste generated during work in designated containers.



2.5.10. Work environment where there has been contact with asbestos-containing materials, should be cleaned up using all necessary protective equipment and a wet cleaning method or asbestos dust collection using a vacuum cleaner with a type H filter.



The workplace should be cleaned using protective equipment and appropriate cleaning methods and equipment.

2.5.11. **If the facility is NOT maintained in good order, VTL has the right to request the responsible Contractor to tidy up the workplaces by a specific deadline/date. If work is performed by several Contractors, the responsible Contractor shall be responsible for ensuring order at the construction site.**



MAINTAINING ORDER AT THE WORKPLACE AND IN PERSONNEL PREMISES

2.5.12. To ensure order at the workplace, the Contractor is recommended to implement the Lean 5S method consisting of 5 steps: *Seiri, Seiton, Seiso, Seiketsu, Shitsuke*.

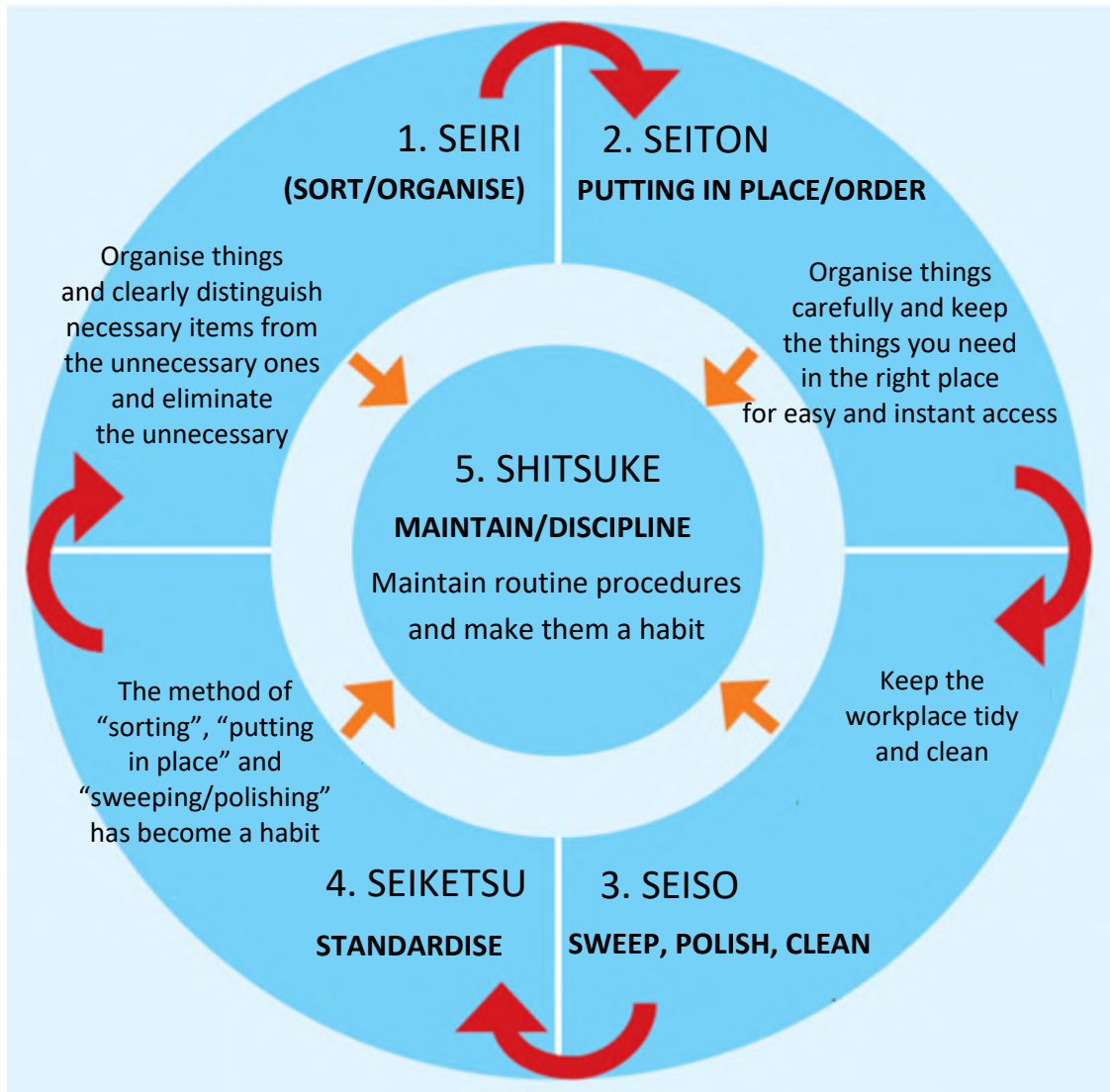

References:

1. <http://www.lean.state.mn.us/photos.htm>
2. <https://www.wshc.sg/wps/themes/html/upload/event/file/3%205S%20MATL%20SKS.pdf>



REQUIREMENTS FOR PREPARING AND EQUIPPING WORKPLACES AND PERSONNEL PREMISES

2.6. Requirements for preparing and equipping workplaces and personnel premises

- 2.6.1. While performing work on the premises of VTL, all Contractors must provide their employees with rest facilities where it is possible to warm up in cold weather or cool down in hot weather.
- 2.6.2. The Contractor is obliged to equip the rest facilities with drinking water, a washbasin, the possibility to heat food, resting areas: benches, chairs, lockers for storing everyday and work clothes, a first aid kit and a fire extinguisher. The first-aid kit and fire extinguisher must not be expired and their location should be marked with a safety sign.
- 2.6.3. Toilets and, where possible, shower rooms, are provided for contractors by VTL.
- 2.6.4. The Contractor's representative agrees with the responsible employee of VTL on arranging personnel premises in one of the buildings of VTL or a location for portable buildings (portacabins) before commencing work.
- 2.6.5. When arranging the workplace and/or personnel premises, take the applicable environmental protection requirements into account.
- 2.6.6. Contractors whose employees use bicycles as their means of transport shall equip the work locations with bicycle parking facilities. Bicycle parking facilities are mandatory if 5 or more employees use bicycles.



- 2.6.7. The following locations shall be agreed with the responsible VTL employee for capital construction projects:
 - 2.6.7.1. office location;
 - 2.6.7.2. location of work premises/personnel premises;
 - 2.6.7.3. locations and methods of storing equipment and materials;
 - 2.6.7.4. warehouse locations;
 - 2.6.7.5. parking areas;
 - 2.6.7.6. types of fencing and other matters.
- 2.6.8. It is not allowed to stack materials in the areas where personnel premises are located. If it is necessary to store materials next to the personnel premises, this must be agreed in advance with the responsible representative of VTL.
- 2.6.9. A representative of VTL responsible for the respective project shall specify the material storage (stacking) locations to the contractor.



REQUIREMENTS FOR PREPARING AND EQUIPPING WORKPLACES AND PERSONNEL PREMISES

2.6.10. It is not permitted to arrange employee rest facilities in warehouse containers and use them as PPE storage locations.

2.6.11. The rest facilities and personnel premises, regardless of whether they are the Contractor's premises or premises designated by VTL, must be kept clean and tidy.



2.6.12. Smoking is not allowed in the personnel premises, except for in locations specially designated by VTL.



DO NOT SMOKE OUTSIDE DESIGNATED SMOKING AREAS

- Smoking is only allowed in specially designated smoking areas.
- Know where smoking areas are located.
- Intervene if you see someone smoking outside the permitted smoking areas.

2.6.13. For smoking, there are special containers on the premises of VTL marked with safety signs, as well as designated areas. These containers are located near FRSS and next to the Repair Workshop. A special place has been established next to the Repair Workshop.





REQUIREMENTS FOR PREPARING AND EQUIPPING WORKPLACES AND PERSONNEL PREMISES

2.6.14. There are two smoking areas in the square opposite the VTL administrative building, equipped with cigarette receptacles.



2.6.15. It is forbidden to leave the heating devices on unattended in the personnel premises, except for when the personnel premises are equipped with stationary heating devices or their operating conditions are agreed with the Process Safety Engineer of VTL.

2.6.16. If the work involves opening the tank bunding, then the work should be organised so that the bunding is always closed, except for in cases when **there is only one tank inside the bund wall and it is empty**, e.g., undergoing repair or being prepared for repair, etc.

2.6.17. The bunding may only be opened temporarily, for example, to allow machinery to enter, unload materials and perform other temporary activities.

2.6.18. If the machinery must remain inside the bunding for a long time during the work process, the bunding must be closed (supplemented) after the equipment has entered.



OCCUPATIONAL HEALTH OF EMPLOYEES

2.7. Occupational health of employees

- 2.7.1. All Contractors carrying out work at VTL must have a comprehensive occupational safety and health system in place that ensures safe and healthy working conditions.
- 2.7.2. When carrying out work on the premises of VTL, the contractor must appoint an occupational safety officer (safety coordinator) who must be trained in accordance with the law. This person shall control and monitor compliance with the occupational safety requirements during the performance of the work at the facility.
- 2.7.3. All employees of the Contractors must:
 - 2.7.3.1. undergo introductory training and briefing at the workplace in accordance with the requirements of the laws and regulations of the Republic of Latvia;
 - 2.7.3.2. undergo and be familiarised with the work environment risk assessment. Work environment risk assessment must be performed for the types of work and workplaces located on the premises of VTL. Work environment risk assessment must also be performed for workplaces located on the premises of JSC Ventbunkers, if the work has been ordered by VTL.
 - 2.7.3.3. undergo mandatory health examinations in accordance with the work environment risk assessment;
 - 2.7.3.4. be provided with all necessary collective and personal protective equipment;
 - 2.7.3.5. have a plan of occupational safety measures for the current year.
- 2.7.4. VTL is entitled to request the Contractor to present or submit the documents referred to in Paragraph 2.7.3, as well as to perform an audit of the Contractor's occupational safety system.
- 2.7.5. The Contractor has the obligation to IMMEDIATELY report any accident and near-accidents on the premises of VTL or involving the property of VTL to the responsible employee of VTL and to investigate the accident.



INFORMING CONTRACTORS AND TOOLBOX MEETINGS

2.8. Informing Contractors and Toolbox meetings

2.8.1. Vitol Terminal Latvia may engage Contractors to ensure its processes.

2.8.2. In order to inform the Contractors about the current issues of quality, environment, occupational health and safety and other matters, the following activities are organised, in which the responsible Contractors are required to participate:

2.8.2.1. Annual and special briefings regarding safety issues directed by VTL Pass Inspector;

2.8.2.2. monthly safety meetings for contractors, taking place at 10:00 on the second Thursday of the month in the Conference Hall of the Administration Building (3rd Floor), discussing safety and occupational health issues relevant to the company;



2.8.2.3. special (ad-hoc) meetings organised by responsible employees of VTL to resolve specific problem situations or events, in which the employees of contractors also participate;

2.8.2.4. meetings organised by contractors for their employees concerning relevant information received during the safety meeting, among other current topics. If necessary, the responsible employees of VTL may be invited to the meetings to better explain the situation or problem;

2.8.2.5. Safety "Stand UP" events organised by VTL immediately after a serious accident;

2.8.2.6. VTL has provided a meeting room on the 2nd floor of the Repair Workshop for holding the meetings referred to in Paragraphs 2.8.2.3 and 2.8.2.4;

2.8.3. Informing about quality, environment, occupational health and safety and other current issues may also take place in a virtual environment, such as Microsoft Teams (MS Teams);

2.8.4. Records of all meetings are kept using the form VTL-13.FM.035 "Minutes of meeting with contractors". If decisions on further necessary actions arising from current issues, recommendations, ideas and solutions are taken at the meeting, this shall be noted in the relevant field of the meeting minutes. The original of the minutes is signed and submitted to the VTL Health and Safety Specialist for storage;

2.8.5. If the Contractor considers that there is room for improvement in the organisation of the VTL's work or in any other area, he may register his suggestion in the electronic system "Gurufield" (<https://vtl.gurufield.com/>), either signing up or anonymously.



INFRINGEMENTS BY CONTRACTORS

2.9. Infringements by Contractors

- 2.9.1. If the Contractor or its employees violate the applicable safety, environmental and occupational protection requirements, including the “Life-Saving Regulations”, during the performance of work, VTL is entitled to impose fines according to the provisions of the cooperation agreement. The extent of the fine for an infringement shall be decided by the VTL management team, taking into account the significance of the violation. The extent of the sanctions is determined according to Appendix 2 of the VTL Contract – “Sanctions for violations of environmental protection, fire safety, electrical safety, occupational safety and internal procedure requirements during the performance of contract work”.
- 2.9.2. For each recorded violation, a protocol-statement “On violations of environmental protection, fire safety, electrical safety and occupational safety during the performance of contract work at Vitol Terminal Latvia shall be drawn up. The protocol-statement shall describe the details of the infringement and contain attached photographic or video evidence in a form acceptable to the Contractor.
- 2.9.3. Each recorded and documented infringement shall be reported to the responsible representative of the Contractor who shall sign the protocol-statement to confirm they have been informed.
- 2.9.4. The Contractor is obliged to inform VTL staff about the environment and work environment risks that the Contractor may pose to VTL staff, environment or property by including them in the work plan/work project (where required) and/or in the text of the agreement or any other acceptable way.
- 2.9.5. Within 10 days from the receipt of the summary of recorded infringements, the Contractor is obliged to provide a written plan of corrective and preventive actions to ensure compliance with safety requirements during the performance of work.



2.10. Work supervision

2.10.1. VTL has introduced the practice of work supervision, including at the locations of work of the Contractor.

2.10.2. The requirements at the Contractor facilities are fulfilled and supervised by:

2.10.2.1. **VTL Safety Coordinators** – VTL employees who inspect the Contractors' workplaces and work performance in accordance with the requirements specified in the work permit and the work performance project or task risk analysis several times a day, as well as give permission to commence work. The safety coordinator is authorised to suspend work if the applicable requirements are not complied with. The functions of the VTL safety coordinator are performed by: FRSS shift manager and their assistant, health and safety specialist, process safety engineer.

2.10.2.2. **The responsible employee of VTL** – manages the project from VTL's side and is the main contact person for the Contractor.

2.10.2.3. **VTL employees who perform safety inspections** – FFRS employees who inspect the VTL premises, including the facilities of Contractors.

2.10.2.4. **Auditors** – during the audit, auditors (internal, external) visit the VTL facilities, ask the Contractor's employees questions, check the documentation.

2.10.2.5. **Participants of VTL safety observation rounds** – at least twice a year, all VTL employees visit one of the VTL facilities where work takes place, including a Contractor's facility. The participants of the rounds inspect the facility in the presence of the Contractor's responsible employee, check compliance with the requirements in accordance with the Permit to Work. During the rounds, the employees may point out any shortcomings found and the Contractor's representative may provide arguments in the case of disagreeing with the views of the participants of the rounds.

2.10.2.6. **Inspections by state and local government institutions** – extraordinary and thematic inspections by state and local government inspectors, during which the facilities where the Contractor performs work may be inspected, and documentation and other information may be requested.

2.10.2.7. **Contractor's representative** – the Contractor shall appoint the responsible representatives and provide their telephone number. These persons must be available at all times. The responsible supervisor or assistant appointed by a decree must ensure its presence during the execution of the work if this is specified in the work performance project.

2.10.3. All shortcomings observed during the facility inspection are recorded in the Gurufield system or in audit reports.

2.10.4. If there are more than two contractors, the main Contractor shall appoint an **occupational safety coordinator** at the facility.

2.10.5. If several contractors work at the same facility at the same time, the responsible representative of VTL shall appoint the main contractor. The other contractors may only carry out work at the facility with the prior agreement of the main contractor.

2.10.6. If the Contractor discovers infringements of occupational safety, environmental protection or fire safety on the premises of VTL, they shall inform the VTL safety coordinator or their contact person assigned by VTL, or shall register the report in the electronic system Gurufield.



SAFETY SIGNS

2.11. Safety signs

2.11.1. Vitol Terminal Latvia is an increased hazard facility where different types of work take place, including high-risk work. All employees of the Contractor must observe the applicable restrictions and warning signs, as well as mark dangerous locations at their workplace with safety signs (prohibition, warning, mandatory signs).



2.11.2. At any facilities where the work will take place for 5 days or longer, the Contractor is required to install an information sign containing the following information: name of the facility, name of the Contractor, name and contact telephone number of the responsible supervisor, warning signs about hazardous conditions and risk factors on the construction site.

CAUTION! CONSTRUCTION WORK IN PROGRESS!
OBSERVE LABOUR PROTECTION AND FIRE SAFETY REQUIREMENTS!

 SAFETY HELMET MUST BE USED	 PEDESTRIAN MOVEMENT PROHIBITED	 MOVEMENT OF UNRELATED PERSONS PROHIBITED	 GENERAL HAZARD!
 SAFETY GLASSES MUST BE USED	 SMOKING AND OPEN FLAME PROHIBITED	 SMOKING PROHIBITED!	 DANGER, ELECTRICITY

Object title: TSI CONSTRUCTION WORKS
Responsible subcontractor: SIA Māja
Responsible foreman: J. Ozols, cont. tel. 26333678

2.11.3. The safety sign shall be placed at the employee's eye level (to be noticed) in the vicinity of the respective hazardous facility, in an easily accessible place, noting any obstacles, as well as access to exits in the case of emergency. It is forbidden to place any objects or park vehicles in the area where safety signs are located to avoid the risk of covering them.



PROTECTIVE EQUIPMENT

2.12. Protective equipment

2.12.1. While working on the premises of the company, the Contractor must supply the employees with appropriate personal and collective protective equipment to ensure that the work is performed in a safe manner.

2.12.2. While working at the Terminal, the Contractor's employee must, as a minimum, be equipped with and use the following personal protective equipment:

2.12.2.1. antistatic (EN 1149) work clothing with long sleeves and trousers or overalls with embedded reflective elements (EN 471) at the top/bottom of the garment. The name of the Contractor must be indicated on the clothing (or helmet). The contractor must have a certificate attesting the compliance of the materials with the standards EN1149 and EN 471, which must be presented at the request of VTL;

Working environment/type of work	Clothing properties **	Pictograms	Compliance with the standard
Work in the process zone and green zone, except for the works listed below	Antistatic, with reflective elements		EN 471; EN 1149; EN 11612
Flame work – welding, gas cutting	High-temperature resistant		EN 1149; EN 11611
Work in direct contact with petroleum products, including remediation work and cleaning of process equipment	Antistatic, with reflective elements, oil-resistant, non-flammable*		EN 1149; EN 471; EN 14605;
Work in direct contact with petroleum products (gasoline, ethers, alcohols), e.g., cleaning of process equipment, taking samples, installing valves, etc.	Antistatic, chemically resistant (gasoline-proof)		EN 1149; EN 471; EN 14605;
Sandblasting and painting work	Antistatic, protection against small splashes/droplets, particles		EN 1149; EN 13982-1; EN 13034
Contact with asbestos	Antistatic with protection against solid particles		EN 1149; EN 13982



PROTECTIVE EQUIPMENT



Reflective elements are embedded at the top and bottom of the garment, and the work clothing and/or the helmet of the employee features the name of the company.

2.12.2.2. Special work footwear with a hard toe cap, without metal elements (nails or heel that can cause sparks), with a non-slip sole; the footwear must comply with protection class S3.

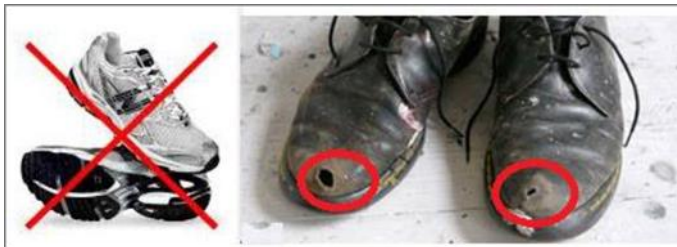

Working in casual footwear, as well as in worn or damaged work footwear is not allowed

2.12.2.3. safety goggles in accordance with the requirements of standard EN 166;

Frame marking
(example):
D 166 3 B T

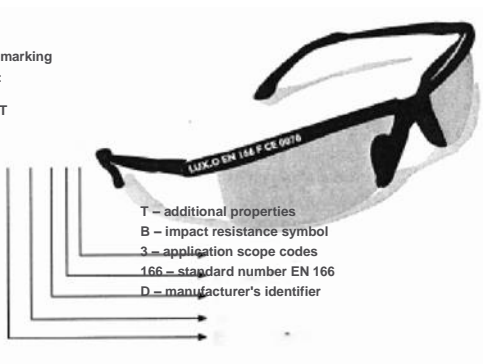

Safety goggles, including optical goggles, complying with EN 166



PROTECTIVE EQUIPMENT

2.12.2.4. protective gloves with appropriate protection for the work conditions – mechanical protection, chemical protection, etc.;

2.12.2.5. safety helmet with a valid shelf life (for a standard helmet the shelf life is 5 years). The validity period for each safety helmet is determined by the manufacturer.

2.12.3. The Contractor may deviate from the requirements set out in Paragraph 2.12.2.1 (anti-static work clothing) in agreement with the representative of SIA "Vitol Terminal Latvia", taking into account the specifics of the work and the place of execution. In such cases, full responsibility for compliance with the deviations shall rest with the VTL representative who gave approval for the deviations.

2.12.4. In addition to the protective equipment specified in Paragraph 2.12.2, the Contractor shall provide all necessary protective equipment for protection against risk factors in the working environment, such as noise, vibration, work at height, chemical (carcinogenic) products, etc.

2.12.5. The most common work environment risk factors at VTL are:

2.12.5.1. noise – working without ear protection is permitted if the noise level does not exceed 80 dB;

2.12.5.2. vibration – while working with various power tools and pneumatic tools (vibratory compacter, angle grinders, demolition hammers, impact wrenches, high-pressure washers, etc.), employees must be provided with appropriate vibration reducing or anti-vibration gloves;

2.12.5.3. work higher than 1.5 m from a stable foundation – a full-height anti-fall harness with one or two ties (absorbing or non-absorbing), depending on the work specifics, must be used. All PPE used as protective equipment for work at height must be inspected by the competent authority;



This type of harness does not provide the necessary protection in the event of a fall

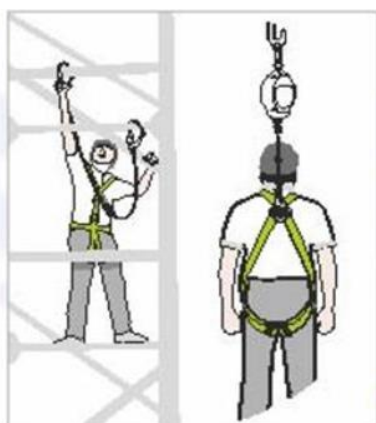

Suitable harness for work at height, as it provides protection for the body in the event of a fall



PROTECTIVE EQUIPMENT

- 2.12.5.4. work closer than 1 metre from water – a life jacket must be worn. The life jacket must be verified by a competent authority.
- 2.12.5.5. cutting trees and shrubbery – wear special work clothing, footwear and protective gloves protecting the employee while using a chainsaw;
- 2.12.5.6. dust in the form of solid particles:
 - 2.12.5.6.1. respiratory protection – half mask or full face masks with P-class filters depending on the type and concentration of dust in the air of the work environment. The use of maintenance-free respirators is only allowed for short-term work with a low concentration of dust in the air of the work environment;
 - 2.12.5.6.2. body protection – disposable antistatic, protective clothing for protection against solid particles;
 - 2.12.5.6.3. hand protection – protective gloves;
- 2.12.5.7. splashes, vapours, gases of chemical substances, including carcinogens:
 - 2.12.5.7.1. respiratory protection – half mask or full face masks or motorised air-filtering mask with appropriate class (such as ABE) filters depending on the chemicals in the air of the work environment.
 - 2.12.5.7.2. compressed air breathing system or apparatus or supplied air hood;
 - 2.12.5.7.3. body protection – antistatic protective suit for protection against chemicals in the form of splashes, droplets or the effects of high pressure (at least Category 3, and protection class types 3, 4, 5 or 6);
 - 2.12.5.7.4. hand protection – chemically resistant (according to SDS) safety gloves;
 - 2.12.5.7.5. dust and chemical splashes, vapours, gases – the protective equipment used should be intercompatible or provide joint protection.



PROTECTIVE EQUIPMENT

2.12.6. It is permitted to use personal protective equipment that has undergone periodic inspections and has a valid shelf life.

Name of PPE	Shelf life/frequency of inspections	Note
Safety helmet	5* ** years	The helmet is marked with the date of manufacture – year and month
Chemical protective suits	Until worn out	Physical defects – holes, wear
Protective footwear	Until worn out	Worn to metal protective plates, toes or soles, etc.
Safety goggles, visors	Until worn out	scratched lenses, broken
Full-height anti-fall harness	examined 1x per year	Each harness has a shelf life
Safety ties	examined 1x per year	Each system has a shelf life
Life jackets	examined 1x per year	
Lifebuoys	examined 1x every 10 years	
Half mask or full-face mask	5 years	The masks are marked with the date of manufacture
Gas/vapour filters	The shelf life is marked on the packaging. The filter is used up, breathing through it becomes difficult.	The filter starts performing its function once the packaging is opened, therefore the filter will become unusable if the packaging is opened but the filter is not used
Maintenance-free particulate respirators	Disposable if marked with NR (<i>Non Reusable</i>); Reusable if marked with R (<i>Reusable</i>).	

** if the safety helmet has been subjected to a severe impact, it is rendered unusable regardless of its shelf life*

*** The shelf life of the safety helmet may also be shorter or longer. It is determined by the manufacturer of the helmet.*

2.12.7. Any deviations related to the change or replacement of the prescribed protective equipment, taking into account the probability of work environment risk factors and the employee's occupational health, shall be approved by the Contractor in writing with the VTL EHS service manager.

2.12.8. The Contractor is obliged to provide suitable conditions for the storage of protective equipment. Respiratory protection and work clothing must not be stored together with chemicals (primers, solvents, paints, varnishes, etc.) or in a dusty environment.



PROTECTIVE EQUIPMENT



Improper storage of protective equipment

2.12.9. Personal protective equipment must be worn by all employees working in the area exposed to risk, for example, when using an angle grinder, hearing and eye protection must be worn not only by the employee using the tool, but also by the employee standing by and assisting.



In order to ensure full protection of the occupational health of the employee, all required protective equipment must be used



POWER TOOLS AND CABLE MANAGEMENT

2.13. Power tools and cable management

2.13.1. A power tool is a device that requires a power source to operate.

2.13.2. VTL has imposed restrictions on the use of power tools depending on the zoning of the premises:

2.13.2.1. **In the green zone** – power tools in working order, without damaged insulation;

2.13.2.2. **In the process zone** – power tools in working order, without damaged insulation or housing. Unless they are explosion-proof, they can only be used if a Permit to Work has been drawn up.

2.13.3. The use of a power tool in the process zone must be approved by the responsible employee of VTL – electrical installation operation engineer and a Permit to Work must be drawn up. Use of any electrical equipment outside buildings without approval is prohibited.

2.13.4. VTL only provides the Contractor with a connection point for the connection of the portable construction site distribution gear. Other equipment required for work (distribution gear, extension cords, tools, etc.) is provided by the Contractor itself.

2.13.5. All power tools or electrical equipment, except those powered from batteries, must be serviced/inspected as evidenced by an inspection certificate or an internal report prepared by the holder of the tool/equipment certifying that the tool has been inspected and is safe. Such inspections must be carried out within the intervals specified by the manufacturer of the tool/equipment, but at least **once a year**.

2.13.6. If the tool/equipment is rented, such proof must be requested from the lessee. If the lessee is unable to provide such proof, this equipment must be inspected by the Contractor. Without an inspection, operation of the equipment will not be allowed.

2.13.7. Before connecting the tool to the mains, the employee must make sure that the mains voltage corresponds to the voltage and rated power of the tool.

2.13.8. The cable management must be kept in order and cables must be protected against accidental damage or entanglement in traffic areas in the workplace. On road and path crossings, cables must be protected against mechanical damage. Cables on the premises must be laid on a tripod, it is prohibited to bury them. If the cable needs to be laid in the ground, this can only be done with the approval of the responsible representative of VTL.



Covered or elevated cables in traffic areas



POWER TOOLS AND CABLE MANAGEMENT



Messy cables

2.13.9. Tools and cables must not be left in moisture (water), including the elements, unless specified otherwise in their technical specifications;



Electrical cables being used in an unsuitable working environment

2.13.10. For outdoor use, power tools (e.g., extension cords) with a protection class of at least **IP 44** are permitted. Power sockets must be fitted with covers;

2.13.11. The following requirements are set for electrical extension cords, in addition to those specified in Paragraph 2.10.10:

2.13.11.1. the cross-section of the wires must not be less than 2.5 mm² if the extension cord is intended for power tools and 1.5 mm² if it is intended for lighting;

2.13.11.2. the cross-section of the wires must correspond to the total rated power of the equipment used;

2.13.11.3. extension cords or temporary wiring must be completely unwound from the coil, except for cases when the manufacturer has provided otherwise;

2.13.11.4. extension cords or temporary wiring must be free of defects and modifications. Only modifications to avoid dangerous transient resistance or electric shock to the employees are permitted.



POWER TOOLS AND CABLE MANAGEMENT



Cables connected for temporary use and are unsafe, which can lead to dangerous situations



The electrical cables are connected correctly using heat-shrink sleeves

2.13.12. Power sockets in temporary electrical installations and construction switchboards that can be connected to several voltage levels must be labelled with their respective voltage. For extra attention, power sockets should be colour-coded.

2.13.13. If different users are connected to the same VTL switchboard, for example, VTL and the contractor, the cable at the power socket should be labelled with the user of the cable (company).



POWER TOOLS AND CABLE MANAGEMENT



2.13.14. Electrical equipment and all metal parts that may become live must be earthed. Electrical appliances and power tools must be CE marked and bear the “square in square” (double insulation) symbol.



The tool bears a conformity mark indicating double insulation

2.13.15. The plug of the power tool must be suitable for the mains socket. No modifications to the design of the plug are permitted.

2.13.16. All power tools must be disconnected from the mains during breaks and at the end of the working day.

2.13.17. It is not permitted to lock the safety switch of the power tool or work with the safety guard removed.

2.13.18. Before connecting the tool to the mains socket, its switch must be in the “Off” position. It is also not permitted to use the tool if its switch is damaged.

2.13.19. When working with rotating power tools, workers must not wear loose-fitting work clothing or jewellery and must avoid hair, clothing or gloves being pulled into the moving parts of the tool.



POWER TOOLS AND CABLE MANAGEMENT

- 2.13.20. If during work, the tool produces noise exceeding 80 dB or dust, all employees in the working area (up to 1.5 m) must wear appropriate hearing and respiratory protection.
- 2.13.21. Any operations related to adjusting the tool or replacing worn parts can only be performed by workshops. When repairing tools, they must be disconnected from the power supply.
- 2.13.22. Where cables are placed over existing structures, including reinforced concrete bunding, spacers must be placed between the cables and the structure so as to avoid friction damage to the cables.
- 2.13.23. If, after connecting a tool (or equipment) to a power source and switching it on using a circuit breaker, it immediately shuts off, the contractor must promptly notify the VTL electrical systems operations engineer. Further actions are permitted only after the equipment has been inspected by VTL and approval has been granted.



2.14. Locksmith hand tools

2.14.1. VTL has imposed restrictions on the use of locksmith hand tools depending on the zoning of the premises:

2.14.1.1. In the green zone – hand tools in working order, without burrs, dents, cuts, cracks;

2.14.1.2. **In the process zone** – hand tools in working order, **spark-proof**, without burrs, dents, cuts, cracks.

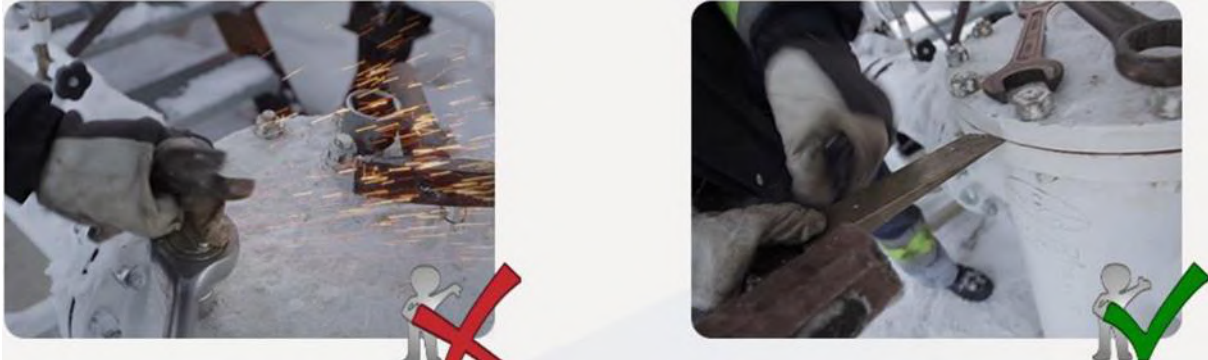

2.14.2. It is not permitted to use hand tools with the safety guards removed, if equipped.

2.14.3. Where large quantities of small hand tools need to be carried from one place to another, they should be accurately placed in a toolbox or bag without throwing.

2.14.4. A tool must never be thrown, it should be handed over from hand to hand or placed at the intended location.

2.14.5. During breaks, hand tools must not be left in such a way that they may pose a risk to the employee and should not be thrown in a pile, including together with wiping material or work clothing.

2.14.6. It is not allowed to leave tools, small parts, screws and nuts on or inside the equipment to be repaired.

2.14.7. Use appropriate size wrenches to loosen nuts.

2.14.8. It is not permitted to use hand tools, the original shape/appearance of which have changed (bent, curved to one side, etc.).

2.14.9. The Contractor must check the compliance of the hand tool to VTL safety requirements before use.



FIRE EXTINGUISHERS

2.15. Fire extinguishers

2.15.1. There is a mandatory requirement for workplaces on the premises of VTL to be equipped with fire extinguisher(-s).

2.15.2. It is allowed to use **carbon dioxide** and **powder** fire extinguishers on the premises of VTL.



3.8.2.1. **The powder extinguishers** are suitable for extinguishing all types of small fires, including fires of electrical equipment with voltage up to 1,000 volts;

3.8.2.2. **Carbon dioxide extinguishers** are better suited for extinguishing electrical equipment with voltage up to 1,000 volts because extinguishing a burning object does not damage adjacent equipment.

2.15.3. Fire extinguishers must be located in such a way that they are clearly visible and freely accessible. Fire extinguishers located indoors must be marked with a safety sign and positioned so that the handle of the fire extinguisher is not higher than 1.5 metres from the ground.



The fire extinguisher cannot be freely accessed



There is unobstructed access to the fire extinguisher and the location of the extinguishers is marked

2.15.4. Certified (bearing CE mark), tested and undamaged fire extinguishers can be used at VTL:



FIRE EXTINGUISHERS

2.15.4.1. The extinguisher must have a valid inspection expiry period as evidenced by a sticker on the fire extinguisher. The business providing the maintenance of the fire extinguishers must be certified.

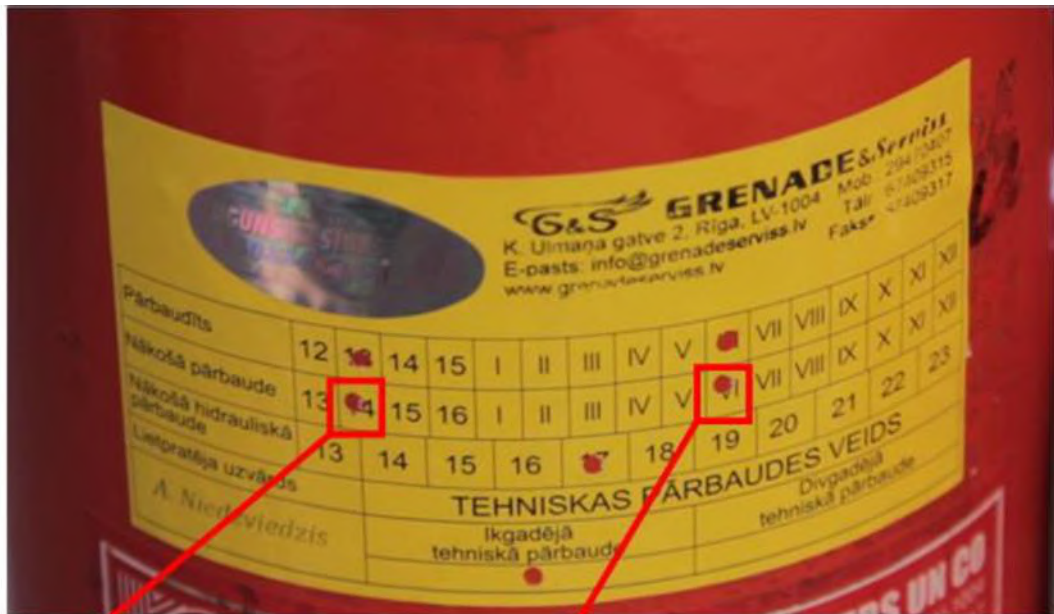

Year until which the inspection is valid

Month until which the inspection is valid

The fire extinguisher is certified until June 2014

2.15.4.2. The fire extinguisher must be properly sealed, with no visible damage (exhaust hose, siphon or housing), free of rust, dents or pressure gauge damage. The pressure gauge must be in the green sector and the information on the fire extinguisher must be clearly legible.



Unauthorized replacement of the seal blocking the triggering of the extinguisher





FIRE EXTINGUISHERS

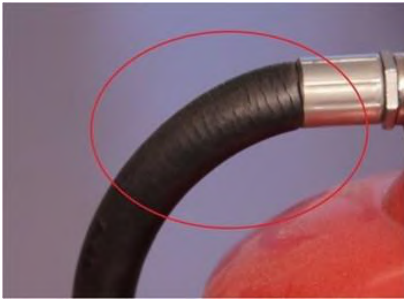

Cracked hose



The pressure gauge of the fire extinguisher is damaged and the information about the certification period and performed inspections is damaged and illegible



2.15.5. Fire extinguishers located at the premises and facilities of the company must not be removed and moved to another location. An exception is an emergency situation.









2.15.6. When performing work or entering the premises of VTL, a minimum number of fire extinguishers is required depending on the nature of the work. The required number and type of fire extinguishers are specified in the Permit to Work.



FIRE EXTINGUISHERS

2.15.7. The minimum number of fire extinguishers in vehicles when entering the premises of VTL.

<p style="text-align: center;">Cars</p>  <p style="text-align: center;">1 fire extinguisher with an extinguishing capacity of 5A 21B (PA1)</p>		<p style="text-align: center;">1 kg</p>
<p style="text-align: center;">Passenger vehicle, truck, large car and tractor equipment</p>  <p style="text-align: center;">Fire extinguishers or extinguishers with a total extinguishing capacity of 27A 70B (1 PA6 or 1PA4 or 1PA2)</p>	 <p style="text-align: center;">4 kg</p>	<p style="text-align: center;">or</p>  <p style="text-align: center;">2 kg</p>
<p style="text-align: center;">Vehicles carrying dangerous goods</p> <p style="text-align: center;">Number of fire extinguishers according to ADR in Paragraph 8.1.4.1</p>	<p style="text-align: center;">or</p>  <p style="text-align: center;">6 kg</p>	



CHEMICAL SUBSTANCES AND THEIR USE

2.16. Chemical substances and their use

2.16.1. Taking the hazards of the chemicals or their mixture into account, the operator must exercise care and caution and take the necessary measures to prevent harm to the environment, human life, health and property. Observe the applicable hygiene and environmental protection requirements when storing chemicals at the work location.

2.16.2. Vessels containing chemicals must be labelled with the name of the substance. A name corresponding to the contents of the container is also required for chemicals that are not hazardous to the health or life of the employee.



Chemicals stored in reused containers that are not labelled with the name of the chemical

2.16.3. In the case of hazardous chemicals or mixtures, an appropriate pictogram must appear on the packaging in addition to the name of the chemical or mixture. A hazard pictogram is an image on the label that includes a warning symbol and special colours to provide information about the harm that a particular substance or mixture may cause to our health or the environment.

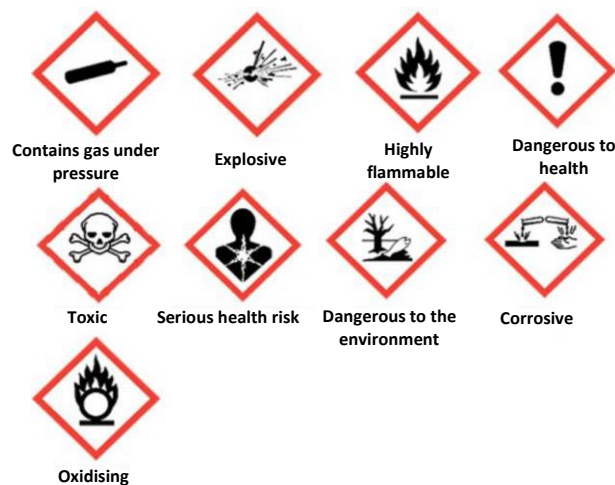



CHEMICAL SUBSTANCES AND THEIR USE



Drums with chemicals cannot be identified and are not stored properly

2.16.4. The contractor must ensure access to safety data sheets (SDS) of the chemicals used at the work site (VTL premises and sites). These locations must be identified and clearly visible so that the staff of VTL Fire, Rescue and Security Service can quickly access the necessary safety and response information in emergency situations.



Safety data sheets placed in a location visible to employees

2.16.5. Prior to commencing work, the SDS must be made available to all employees of the Contractor who use the particular chemical.

2.16.6. Based on the safety requirements specified in the Safety Data Sheet, employees must be provided with appropriate protective equipment for contact with the chemical, and the employees must be able to use appropriate protective equipment correctly.

2.16.7. Proper storage of the chemical must be ensured taking the composition and properties of the chemical into account.



Proper storage of chemicals – safety signs in place, safety data sheets available, substances labelled



WORK PERMITS AND THEIR TYPES

3. WORK PERMITS

To ensure safe performance of the work, the Contractor must obtain a work permit – Permit to Work. Obtaining a work permit is not necessary for the following types of work:

- work related to the ensuring normal production process using the existing technological infrastructure;
- equipment repair in the vehicle (Fire, Rescue and Security Service) department;
- replacement of light bulbs in administration and personnel premises;
- various housekeeping work in administration and personnel buildings;
- geodetic work in the green zone of the terminal; extraction pumping work with a vacuum tanker;
- work in the Repair Workshop and its territory using the equipment and devices installed there;
- work related to the cleaning and landscaping of the premises and buildings of the terminal, except for mowing grass and trimming shrubbery;
- work related to the maintenance of laboratory equipment.
- works related to the cleaning and lubrication of switches on VTL railway feeder lines. Before starting this work, the Operations Shift Leader and the person responsible for the VTL railway infrastructure **MUST** be informed.



WORK WITH A VALID WORK PERMIT



Many types of work can only be commenced with a work permit. Obtain a valid work permit from the supervisor before starting work.

- The work permit sets out the conditions for taking action to ensure that the work is carried out in a safe manner.
- Understand, be aware of and comply with the requirements specified in the work permit.
- Check to make sure your work permit is valid.
- Regardless of a valid work permit, always confirm with your direct superior or supervisor that it is safe to commence work.
- If the conditions, type or extent of work changes, a new work permit is required.



WORK PERMITS AND THEIR TYPES

3.1. Types of work permits

3.1.1. **Permit to Work (PTW)** – a special written permit for the performance of work, including the performance of hot works. Hot works is any work that generates a flame, sparks or heat. It may include work such as cutting, welding, grinding, sandblasting, and the use of explosion-proof electrical equipment in an explosive environment/area.



A Permit to Work shall be drawn up for all types of work



Hot works

3.1.2. **Earthworks, works in confined spaces and on electrical installations** require an additional permit which is considered to be an appendix to the Permit to Work depending on the planned work.

3.1.3. **Permit for earthworks** – special written permit for earthworks. This permit is additionally drawn up as an appendix to the Permit to Work if it contains a note “Earthworks”. A sample of the permit form is available in the “Permit for earthworks” annexed to the guidelines.



If earthworks take place at a depth of more than 1.5 metres, a permit for access to confined space must be drawn up in addition to the earthworks permit.



WORK PERMITS AND THEIR TYPES

3.1.4. **Permit for access to confined space** — a special written permit to access an enclosed space. This permit is additionally drawn up as an appendix to the Permit to Work if it contains a note “Work in confined spaces”. A sample of the permit form is available in the “Permit for work in confined spaces” annexed to the guidelines. Permit for work in confined spaces/areas is valid for one working day. If access to an enclosed space is not related to the performance of work, there is no need to draw up the Permit to Work – the Permit for work in confined spaces is sufficient.



Detailed explanation of what an enclosed space is and the requirements for working in it can be found in the chapter “Work in enclosed space”.

3.1.5. **Permit to Work on electrical installations** – a special written permit to work on electrical installations. This permit is additionally drawn up as an appendix to the Permit to Work if it contains a note “Work on electrical installations”. A sample of the permit form is available in the “Permit to work on electrical installations” annexed to the guidelines.



Entering and working on electrical installations is only permitted after obtaining a special permit.

3.1.6. **Permit for connection of electrical appliances.** If the connection of portable electrical appliances is required for the performance of work, the person requesting the PTW sends a request by e-mail to the Electrical Facilities Operation Engineer. The connection of portable electrical equipment shall be organised by the Contractor's employees after obtaining a written (electronic, by e-mail) assignment from the Electrical Installations Operation Engineer.



DRAWING UP A PERMIT TO WORK

3.2. Drawing up a Permit to Work

3.2.1. A Permit to Work (PTW) is prepared electronically in the ENVIRO system. The assignment can be drawn up by both VTL and the Contractor.

3.2.2. The Contractor shall prepare a PTW upon receiving the work order from the VTL work planner (project manager) or which he prepares himself.

3.2.3. To properly draw up the Permit to Work, the Contractor shall indicate the following information in the ENVIRO electronic system:

- 3.2.3.1. Type of planned work – excavation, work at height, work with hand tools, etc.;
- 3.2.3.2. What additional permits will be required;
- 3.2.3.3. Tools and equipment to be used during work;
- 3.2.3.4. Working methods;
- 3.2.3.5. Detailed description of work;
- 3.2.3.6. Number of employees at the facility;
- 3.2.3.7. Work completion time;
- 3.2.3.8. Name, surname and telephone numbers of the work organiser at the workplace;
- 3.2.3.9. Other information required by the Permit to Work and referred to in Chapter 5 “Hot works” of these guidelines.

3.2.4. If the Permit to Work is drawn up by an employee of VTL, the Contractor submits the information referred to in Paragraph 3.2.3 to the employee of VTL along with any other information requested by the employee of VTL that is required to properly execute the PTW for the performance of work.

3.2.5. Participation in the PTW review meetings if requested by the EHS representative of VTL.

3.2.6. If the ENVIRO system indicates that the work is associated with high risk during the preparation of the PTW, the Contractor's employee is required to prepare a task risk analysis (TRA) for this work together with the Work Planner and the EHS representative.

3.2.7. A Permit to Work is prepared for one specific work order. If the work order which may include several individual tasks.

3.2.8. The Permit to Work is valid for up to 7 (seven) days.

3.2.9. Upon printing each PTW, it is assigned a unique QR code.

3.2.10. At the end of each working day, the Contractor shall present the workplace to the representative of the FRSS for inspection and make a note in the PTW as to whether the work has been completed or not.



DRAWING UP A PERMIT TO WORK

3.2.11. At the end of the work (end of the workday), the contractor must return the PTW to the Operations Shift Leader at the point of issuance – the PTW kiosk. At the kiosk, the contractor scans the QR code and selects one of the following options: "Close Work Permit", "Request Extension", or "Request New Permit", e.g., to extend it for the following week. If the contractor selects "Close Work Permit," the permit is closed and is no longer valid. If "Request Extension" is selected, the permit is extended and can be collected the following day. If "Request New Permit" is selected, a new Work Permit is issued with the same data but a new date and number. Completing the work and closing the Work Permit certifies that the work has been finished, the workplace has been tidied, and the equipment can safely be integrated back into the operational process.

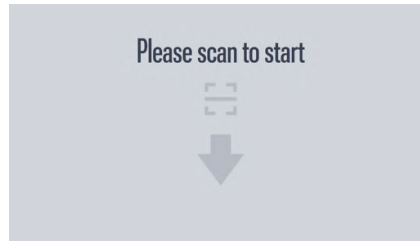

The screenshot shows the VTL PTW software interface. At the top, it displays 'Informācija par darba atļauju un atbildīgo no VTL puses' and 'Darba atļaujas laika uzskaitē'. Below this, there are fields for 'Permit To Work' details: PTW Number: P020314, Status: Issued, Title: Kvalitātes darba atļaujas apraksts, kas apliecinā ieviešot darbus, Valid till: 28.05.2024 19:00, Work Order: 3022017, Planner: Jānis Jēliks, Tel.: 25482292, Executed By: Toms Elmānušs, Arnis Kozars. There are buttons for 'Close Work Permit', 'Request Extension', 'Request New Permit', and 'End Session'. Below this, there is a section for 'Darba atļaujas uzdevumi' (Tasks) with a table listing tasks and their status. The table has columns for 'Darba uzdevums', 'ID', 'Lietojuma atļauja', and 'Status'. The tasks listed are: 'Darba uzdevums 1' (MOV-1148) with status 'Done', 'Darba uzdevums 2' (SEK-402_01) with status 'Done', 'Darba uzdevums 2' (SEK-402_02) with status 'Undo', and 'Darba uzdevums 2' (SEK-402_03) with status 'Done'. At the bottom, there is a note 'Uzņēmums kurš veic darbus' and 'SIA Vitol Terminal Latvia'.

3.2.12. If the contractor scans the QR code and selects "Request Extension" in the log, the same PTW is issued to the contractor the following day (the Permit is located in a designated area that is easily accessible to the contractor). The extension of the Permit is confirmed by the signature and date of the Operations Shift Leader.

3.2.13. The Contractor may carry out the works during the working day from 7.30 to 19.30.

3.2.14. If a longer time is required for the work, the Permit to Work may be extended until 23.30 at the latest. If this deadline is not sufficient, a new Permit to Work must be obtained.

3.2.15. Upon receipt of the Permit to Work, the Contractor is entitled to commence the performance of the works specified in the PTW, except for in cases when the section "PPE and CPE" contains a note that air quality measurements must be performed. In such cases, work may only commence after obtaining clearance from the representative of the FRSS, confirmed by their signature.

3.2.16. Before commencing work, the organiser of the work at the workplace holds a target briefing for the persons involved in the work and makes a corresponding note in the section "Execution of the Permit". The holding of the target briefing for the employees is attested by the signatures of the involved persons. Target briefing is MANDATORY for all employees. Target briefing is performed once, within the specific work and Permit to Work.



DRAWING UP A PERMIT TO WORK

3.2.17. The work organiser makes arrangements at the workplace to ensure a last-minute risk assessment every day before commencing work; this is attested by a corresponding note on the reverse of the Permit to Work in the section “Last-minute risk analysis”.

JĀVEIC PIRMS DARBA UZSĀKŠANAS!

PĒDĒJĀ BRĪŽA RISKA ANALĪZE/ ОЦЕНКА РИСКОВ ПОСЛЕДНЕЙ МИНУТЫ		Datums		Datums		Datums		Datums		Datums		Datums						
		Jā	Nē	N/A	Jā	Nē	N/A	Jā	Nē	N/A	Jā	Nē	N/A	Jā	Nē	N/A		
Riski	Darbiniekiem darba uzdevumi un riski ir izskaidroti./Сотрудникам разъяснены рабочие задачи и риски.																	
	Riskibīstamības ir samazinātas līdz pieļaujamajam līmenim un tiek kontrolēti./Риски / опасности снижены до приемлемого уровня и находятся под контролем.																	
Atļaujas	Meteoroloģiskie laika apstākļi ir atbilstoši darba izpildei (piem. vējš ≥15m/s, u.c.)./ Для выполнения работы подходит метеорологические погодные условия (например, ветер ≥15 м/с и т.д.).																	
	Vai darbiem slēgtā telpā (akas, rezervuāra iekšpusē uc.) ir sagatavota atļauja?/ Есть ли разрешение на работу в закрытом помещении (колоды, внутри резервуара и т.д.)?																	
Droša darba izpilde	Vai ir sagatavots kraušanas plāns, ja tiek plānota kravu pārvietošana?/Есть ли план погрузки, если планируется перевалка груза?																	
	Darbinieki pareizi lieto individuālos aizsardzības līdzekļus (IĀL)./Сотрудники правильно используют средства индивидуальной защиты (СИЗ).																	
	Iekārta atslēgta un/vai bloķēta (LOTO)./Оборудование выключено и / или заблокировано (LOTO).																	
	Vai darbu augstumā var veikt droši?/Возможно ли безопасно работать на высоте?																	
Komunikācija	Vai darba izpildes laikā pastāv kritiāla objekta risks?/Есть ли риск падения предмета во время выполнения работы?																	
	Izmantotie instrumenti un iekārtas pārbaudītas, lietošanai drošas./Использованные инструменты и оборудование проверены, безопасны в использовании.																	
	Vai tehnoloģiskā procesa maiņas vadītājs (D 63666237) ir informēts par darbību, ja tie var ietekmēt tehnoloģisko procesu?/Знает ли руководитель смены технологического процесса (D 63666237) о работках, если они могут повлиять на технологический процесс?																	
	Vai galvenais darbuzņēmējs ir informēts par citiem objektā notiekošajiem darbiem?/Знает ли главный подрядчик о других работах на объекте?																	
	Rīcība ārkārtas situācijās un negadījumā ir zināmas./Известно как реагировать на чрезвычайные ситуации и аварии.																	

3.2.18. If any of the sections of the Permit to Work is full and there is no space for new entries, the Contractor shall obtain a new Permit to Work (with identical information).

3.2.19. The Permit to Work must be stored at the place of work or in the immediate vicinity at all times during the performance of the work. The Permit to Work must be kept safe from the elements or other types of damage.

3.2.20. If the Permit to Work specifies that a unit of the FRSS must be present at the place of work, the Contractor notifies the FRSS shift leader about this no later than 20 minutes before the commencement of work (including resumption of work after breaks longer than 30 minutes), indicating a specific time for the commencement of work. If the work is not commenced within 15 minutes from the specified time due to justified reasons, the FRSS of VTL may leave the post. The Contractor shall be responsible for the downtime and the related expenses caused by such delays.

3.2.21. Permit for earthworks is issued for a period of time that is required for the performance of the work in question, but not longer than for one calendar month. If the work is not completed within one month for justified reasons, it may be extended for another month if the working environment has not changed during this time.

3.2.22. A permit for earthworks is not required for improvement works related to surface gliding, backfilling of trenches and excavation (holes).



DRAWING UP A PERMIT TO WORK

3.2.23. A permit for earthworks is not required if the excavation works are related to the removal of the topsoil (up to 30 cm) and the VTL Electrical Installations Operation Engineer has signed to confirm that the electrical cables have been inspected and the excavation work can proceed safely.

Jāpārbauda elektrokabeļi

Elektrokabeļi pārbaudīti zemes rakšanas darbus var veikt droši

Datums, parakst _____

3.2.24. A diagram of the works with identified potentially dangerous locations must be presented on the reverse of the permit for earthworks.

3.2.25. If the volume of work is so extensive that not all potentially dangerous places can fit in one diagram, then in such cases the works should be divided into stages and a separate permit must be obtained for each separate stage in order to avoid inaccurate diagrams at the place of work.

3.2.26. If the Permit to Work is marked as “High Risk”, a task risk analysis (TRA) process is required before commencing work with the aim of identifying all possible risks during the work that are not covered by the Permit to Work and to determine appropriate mitigation measures.

3.2.27. If it is necessary to lock out equipment during work to ensure safety, then the lockout procedure must be followed.

3.2.28. If the connection of portable electrical appliances is required for the work, the permit for the connection of such equipment shall be issued by the Electrical Installations Operation Engineer. The procedure for requesting a permit to connect an electrical appliance and issuing a permit is specified in Paragraph 3.1.6.



3.3. Workflow of the Permit to work

Reserved



Lock-Out / Tag-Out (LOTO)

3.4. LockOut/TagOut (LOTO)



VERIFY LO/TO BEFORE WORK BEGINS

Ensure the safety of the system or equipment before starting work.



- Danger such as electricity, pressure, gases, hot liquids or radiation need to be considered before you act.
- Before working on the equipment, block the power sources, clean and ventilate it if necessary.
- The fact of lock-out needs to be checked personally by both the workers and the operator.
- Use the Equipment LockOut / TagOut (LOTO) procedure to completely lock the system.
- In case of open equipment or pipeline, provide an operator next to it.
- Ensure regular lock-out check and effectiveness.
- Always use appropriate personal protective equipment.

3.4.1. Lockout/tagout according to the applicable definitions is applied to ensure that the equipment cannot be accidentally switched on/started and the stored energy (electricity, water, oil, gas, steam, etc.) is not released before maintenance or repair work is completed, as well as to ensure **safe work during the maintenance or repair of any equipment**;

3.4.2. Lockout involves installing a suitable mechanical barrier/device that physically prevents the leakage or release of energy, including the flow of the product, while the work is being carried out on the respective equipment or device (tank, pipeline, pump, electric motor, etc.);

3.4.3. The lockout/tagout procedure must be applied to any equipment that may cause any accident by its own energy during the work process;

3.4.4. If the Permit to Work contains a note on the application of the lockout/tagout procedure, the contractor **MUST** make sure that the lockout/tagout has been performed before commencing work. This is evidenced both by tags and physical lockouts or a special lock and key;

Bloķēšanas/ marķēšanas pasākumi

LOTO- elektriskais

Apkārtējie darbības pasākumi

+



LOTO numurs: 201764

Bloķēšanas veids:	1
Izstrādāšanas datums:	2017/01/19
NEPILNĀKĀRĒJĀT!	

Izstrādātājam jānodrošina, ka šīs iekārtas enerģija ir pilnībā izslēgta.

Izstrādātājam jānodrošina, ka šīs iekārtas enerģija ir pilnībā izslēgta.

+



3.4.5. **All employees** must comply with the prohibitions and restrictions applicable to the mechanism (equipment) during lockout. No employee is allowed to turn on, energise or otherwise operate a mechanism (equipment) that has been disconnected (locked out) for maintenance or repair, except for the person who performed the lockout/tagout.



Lock-Out / Tag-Out (LOTO)



Appropriate equipment lockout-tagout

3.4.6. Lockout/tagout procedure

3.4.6.1. Before commencing the lockout/tagout procedure, the Contractors shall obtain the lockout/tagout request information (LOTO Plan), which includes basic information, information on the device to be locked out and the type of lockout/tagout required (electrical or mechanical);

LOTO pieprasījuma informācija			
Pamatinformācija : 002519 RSR - Lielu slēdzēju tīrīšana, pagriezienu atloka demontāža ar krasi ceļma palīdzību.			
(At)bloķējamā ierīce			
TAG-ID : AUK-FP-994	DSU4	Bloķēšanas un marķēšanas pārbaudi veica	Atbloķēšanas un marķēšanas noņemšana pārbaudi veica
Site : Fire Protection		Vārds, Uzvārds: Paraksts:	Vārds, Uzvārds: Paraksts:
Bloķējums un marķējums			
Secība : 1	Apraksts : Iks atslēgta elektrība sadalīt (Detunss/taika	Atslēgta Nr.
Enerģijas avots : Strāva	Bloķēšanu veica		
Statuss : Atslēgts			
Bloķējuma Nr. : 1	Atbloķēšanu veica	Detunss/taika	
TAG-ID : MOA-9600	Ar motoru darbināms pavadis		

3.4.6.2. Agree on the lockout method used together with the LOTO planner;

3.4.6.3. Alone with the LOTO plan, the contractor's employee obtains tagout labels to be placed on the locked-out equipment. Upon receiving the LOTO plan, the Contractor shall provide information on the person who will lock out/tag out the equipment. The information specified in the LOTO plan is contained on the label;

LOTO numurs	001863
Bloķēšanas secība	1
Nobloķēts līdz	31/12/2019
Nobloķēts	

TAG-ID informācija
MLA-09
MLA-09 (MarineLoadingArm)
Stenders 09
Pasākums
 nobloķēšanas uzlikšana starp aizb. 4124/9991 un stenderu Nr
Apraksts
 MLA Nr:9 EMCO sagatavošana pārvietošanai

LOTO pasākuma
 Izstrādājis: [Blank]
 Aizņēma: [Blank]

LOTO pasākuma
 Aizņēma: [Blank]
 Izstrādājis: [Blank]

LOTO numurs	001784
Bloķēšanas secība	1
Nobloķēts līdz	02/12/2019
Atslēgts	

TAG-ID informācija
SWI-SS11_2503
SWI-SS11_2503 [Switch Board / Distribution Board]
Elektrosadales 2-503
Pasākums
 Atslēgt un nobloķēt "EEx rozete 16A" automatslēdzi
Apraksts
 Elektriska aprīkojuma demontāžas un montāžas darbus.

LOTO pasākuma
 Izstrādājis: [Blank]
 Aizņēma: [Blank]

LOTO pasākuma
 Izstrādājis: [Blank]
 Aizņēma: [Blank]

OR

3.4.6.4. Tagout is required to inform the persons involved.



Lock-Out / Tag-Out (LOTO)

3.4.6.5. Equipment has been locked out/tagged out if the equipment is fitted with a lockout/tagout sign and physically locked out, for example, by means of a lockout disc. If such measures are not taken, the Contractor is not allowed to commence work and the situation must be reported to the responsible employee of VTL;

3.4.6.6. After performing tagout/lockout (before commencing and completing), this should be reported to the Operations Shift Leader (mechanical lockout) or electrical installations operation engineer (electrical lockout).

3.4.6.7. Meet an employee of VTL at the facility, who performs a physical inspection of the lockout/tagout procedure – physically making sure that the lockout is correctly implemented and reports the results to the Operations Shift Leader.

3.4.7. Lockout/tagout removal procedure:

3.4.7.1. The lockout/tagout removal procedure may only commence when all PTWs for the performance of works are closed for the equipment in question and it is visually verified that the unlocking procedure can be started;

3.4.7.2. A LOTO plan must be obtained to commence the lockout/tagout removal procedure;

3.4.7.3. Upon receipt of the LOTO plan, remove the lockout/tagout according to the plan;

3.4.7.4. The person removing the lockout reports the fact that the lockout has been removed to the Operations Shift Leader (mechanical lockout) or electrical installations operation engineer (electrical lockout), who in turn organises an inspection of the lockout removal procedure and return of the equipment into the process;

3.4.8. Lockout/tagout workflow:

Reserved



3.5. Task risk analysis

3.5.1. Task risk analysis (TRA) is an appendix to the *Permit to Work*, which systematically identifies risks and mitigation measures that are not effectively controlled by the *Permit to Work*. A sample of the task risk analysis is available in the “Task risk analysis” annexed to the guidelines.

3.5.2. TRA is prepared if the ENVIRO electronic system identifies the work in question as high risk work during the preparation of the Permit to Work. It shall be prepared no later than 24 hours before commencing work.

3.5.3. The TRA must be approved by the EHS manager, the technical manager and the process manager before obtaining the *Permit to Work*.

3.5.4. If the work task has been classified as high-risk, the Permit to Work cannot be printed until a copy of the TRA is attached in the ENVIRO system.

3.5.5. TRA is prepared for a specific facility (work) and is valid until the completion of the facility (completion of work). A PTW is issued on the basis of the prepared TRA.

3.5.6. The TRA is drawn up at a meeting attended by representatives of all parties involved in the work process: Contractor's representative, VTL project manager, EHS representatives and other parties. Participants of the meeting identify the potential risks, their development scenarios, probability of occurrence and possible consequences and a risk assessment is performed using the Risk Assessment Matrix. If the level of risk is high, risk control and mitigation measures are defined, risks are reassessed using the above methodology and the measures are refined until an acceptable level of risk is reached, or a decision is made to abandon work if the risk cannot be reduced.



LAST MINUTE RISK ANALYSIS

3.6. Last minute risk analysis

- 3.6.1. Last-minute risk analysis (LMRA) is the last visual step before commencing work, during which employees assess work-related hazards and the environment.
- 3.6.2. It is an individual or collective process to perform one specific task or the entire scope of work at once in one specific location.
- 3.6.3. The last-minute risk analysis is performed when the Permit to Work has been obtained, all preparations have been made and all protective equipment has been checked and prepared.
- 3.6.4. LMRA is performed every time employees want to commence work, including after each break and when employees feel that the situation has changed.
- 3.6.5. If the Contractor's employee performs the work alone, they shall perform the LMRA independently to make sure that everything is in order and safe before commencing the work process.
- 3.6.6. Last minute risk analysis includes:
 - 3.6.6.1. The work itself that the employee will perform at the specific location;
 - 3.6.6.2. Environmental conditions (hazardous equipment, hazardous manholes nearby, other employees from other companies, colleagues nearby who may interfere with the employee's work or who may be disturbed by the employee's actions);
 - 3.6.6.3. Matters related to action in emergency: Emergency issues: hand signallers, escape masks, emergency showers, first aid kits, etc.
- 3.6.7. All future events cannot be predicted or included in the Permit to Work, therefore LMRA is the last step in detecting hidden hazards and adopting additional security measures;
- 3.6.8. The working environment is constantly changing. The actual situation and conditions at the workplace can be better assessed and understood if the person in charge of the work does it before commencing work together with the employees (workers).
- 3.6.9. Before commencing work, it is necessary to make sure that **ALL RISKS and HAZARDS** are controlled and all necessary preventive and corrective measures to eliminate them have been taken.



TYPES OF WORK – EARTHWORKS

4. TYPES OF WORK

4.1. Earthworks



OBTAIN PERMISSION BEFORE STARTING EXCAVATION WORK

"Excavation" means the removal of any man-made pit, trench, ditch or subsoil (e.g. by excavation or drilling).



- Excavation work is allowed only when a work permit has been received.
- Regardless of a valid work permit, always confirm with your direct superior or supervisor that it is safe to commence work.
- All underground hazards (pipelines, electric cables, communication cables, etc.) must be identified, marked, protected from damage and, if necessary, blocked.
- Follow the requirements specified in the work permit.
- The danger can be invisible. In case of doubt or unforeseen situation, stop work and report to the supervisor.

4.1.1. Earthworks include:

4.1.1.1. Topsoil removal, excavation, earth drilling and earth-moving works.

4.1.1.2. Substrate preparation – sand, crushed stone, pebbles, etc.

4.1.1.3. Improvement works – laying pavement, gravel, asphalt, concrete slab surface.

4.1.2. *Permit to Work* must be drawn up to perform earthworks. See section 3.2 for the procedure for drawing up a permit.

4.1.3. If excavation work is carried out at a depth of 1.5 metres or deeper, the work is considered to be work in a confined space. Requirements for work in confined spaces are specified in sub-section 4.15.

4.1.4. Depending on the depth of the pit and the composition of the soil, it must be reinforced with formwork where employees are working. The edges of trenches may be left without reinforcement if the slope of their edges is at an angle of not less than 45°, as well as where exploratory trenches (prospecting shafts) are made or trenches **up to a depth of 1.2 m** for laying cables or pipelines are dug.



TYPES OF WORK – EARTHWORKS

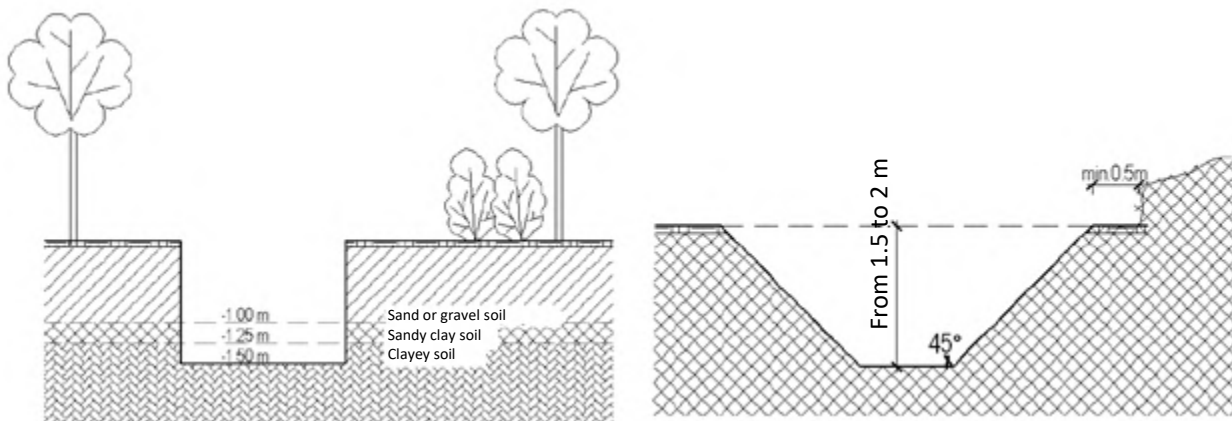

The depth, at which it is allowed to perform work without construction pit wall reinforcement, if the walls are vertical.

4.1.5. If the depth of the construction pit exceeds 4 metres, and there are people performing work in it, the construction pit must be reinforced with shuttering.



Working in construction pits that are more than 1.5 metres deep, without any protection of the edges against collapse, is prohibited!

4.1.6. Both pre-fabricated shuttering and shuttering produced on-site may be used to reinforce trenches. When setting up the shuttering follow the following rules:



TYPES OF WORK – EARTHWORKS

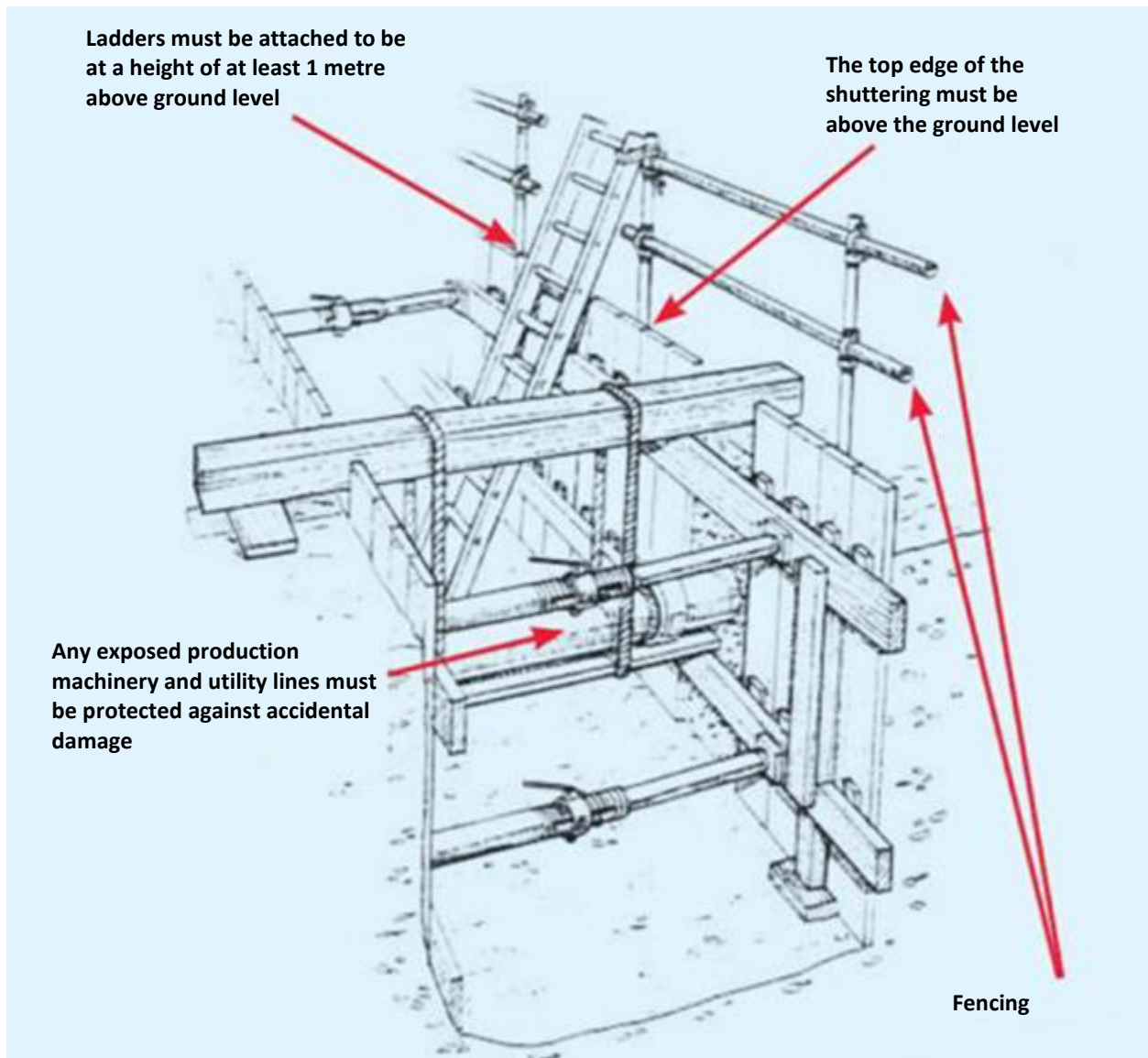

4.1.7. Any construction pits and trenches must be fenced off if they are in a freely-accessible space and their depth exceeds 0.4 metres. The fencing must be placed at a **distance of at least 1 m** from the construction pit or trench.

4.1.8. Whenever digging at pedestrian traffic ways, the pits must be fenced off regardless of their depth, and during night hours, the pits must be provided with a stable, rigid, visible and secure fence, or must be provided with secure covering.

4.1.9. If a number of construction pits/trenches are next to each other, at a distance of no more than 2 metres, they must be provided with perimeter fencing as an entire whole, and not with fencing for each of the trenches individually.



TYPES OF WORK – EARTHWORKS



The fencing of the construction pit is incomplete, and wooden sticks found during the digging were used instead of posts



4.1.10. Durable fencing materials must be used to fence off construction pits.



Fencing materials must be able to withstand poor weather, and need to be repaired if necessary

4.1.11. If poles with sharp ends are used for fencing, the ends must be covered with additional special elements or bent off.



Thin reinforcement rod covered with a PVC cap

4.1.12. Any materials and excavated soil **must not be placed closer than 0.5 m** from the edge of the construction pit.



TYPES OF WORK – EARTHWORKS



Machine placed on the edge of a construction pit

4.1.13. Prior to earthworks, the following measures must be taken that:

- 4.1.13.1. Prevent cave-ins in areas where people work;
- 4.1.13.2. Protect workers from injuries in locations where work is performed using special vehicles or where materials are transported;
- 4.1.13.3. Prevent workers from falling into the construction pits;
- 4.1.13.4. Prevent those working in the construction pits from being exposed to harmful gases or insufficient levels of oxygen;



Fenced-off operating area for a special vehicle

4.1.14. When performing earthworks, it must be ensured that one can safely climb in and out of the construction pit; the number of climb-out locations must match the number of people performing work in the construction pit, to ensure safe escape in the event of an emergency.

4.1.15. If work is performed in a trench, then an escape ladder must be set up in them at an interval of 15 m.

4.1.16. If the performance of work requires crossing trenches or construction pits, they must be provided with footbridges. Such footbridges must have railings.



TYPES OF WORK – EARTHWORKS

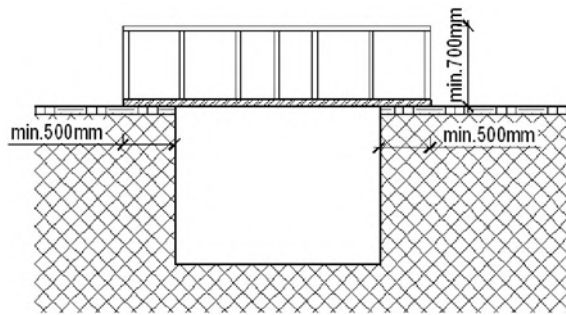

Installation of footbridges across a trench

4.1.17. If excavation necessitates restricting traffic (vehicles and pedestrian), or closing it completely, the party in charge of performing the work reports this to the specialists of the VTL Technical Division. In order to close or restrict traffic in a section of a road, it is necessary to prepare a traffic diagram and place warning signs in the work area.

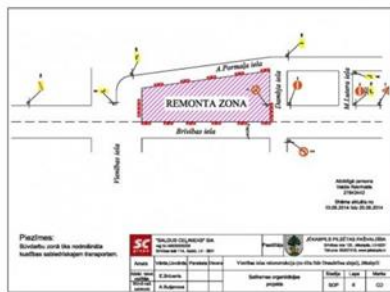

Traffic diagram prepared showing traffic restrictions; installation of warning signs in an area with closed traffic

4.1.18. When performing earthwork any severely polluted soil dug out must be kept separately to prevent repeated pollution of the soil and ground water. Further transportation of the polluted soil must be coordinated with the VTL representative in charge.



Soil severely polluted with oil products must be kept separately, and measures must be taken to prevent the pollution from being rinsed back into soil by rain



TYPES OF WORK – EARTHWORKS



Test pitting done perpendicularly



4.2. Work at height



PROTECT YOURSELF AGAINST FALLS WHEN WORKING AT HEIGHT



Special safety measures must be taken when performing work at height:

- Set up fall protection: a bridge, railings, or a fall protection line (rail).
- If the work area is not equipped with collective protective equipment at the height at which the work is to be performed, personal protective equipment must be used.
- Scaffolding must be inspected and checked by a properly trained worker. Scaffolding must be provided with labels with details on the inspections carried out (it is prohibited to operate uninspected scaffolding).
- Scaffolding may only be assembled and disassembled by trained workers using appropriate personal protective equipment: a fall protection belt with two lanyards.
- Make sure that the rescue plan is available, and everyone knows what it says.
- Do not work alone.

- 4.2.1. Work at height is any work performed at a height of 1.5 m or more from a safe and stable surface. The surface of liquids or loose substances is not considered a safe and stable surface.
- 4.2.2. Performing work at height is prohibited if the wind speed exceeds **15 m/s**.
- 4.2.3. The employees of the contractor that perform work at height must undergo external training for work at height at least once every 5 years, in a licensed training facility; and annually an internal training, certified by the organisation's training protocol or certificates.
- 4.2.4. When performing work at height, the workplace must be equipped with collective protection equipment to prevent the worker from falling, drowning or suffocating.



Fall protection net or stable and secure railings

- 4.2.5. At workplaces where one cannot set up collective protective equipment, workers must use personal protective equipment.



WORK AT HEIGHT



In the event of a fall, a belt will not protect the worker, and will instead snap the worker in half



Correctly using a full-body fall protection harness will protect the worker from injuries in the event of a fall

- 4.2.6. If during the work, the worker must transition from one anchor point to another, two lanyards must always be used to ensure continuous connection to an anchor point.
- 4.2.7. The anchor point must be able to withstand a load of at least 12 kN/1200 kg.
- 4.2.8. All open surfaces or areas, into which one can fall, or from which one can fall, must be fenced off or covered. The fencing must be placed at a distance of no less than 1 m from the edge of the opening. The fencing must prevent the physical possibility of falling into the opening, e.g. through the use of stable fences and barriers. The fencing must be at least 1.1 m tall.



Workers can fall into open and uncovered areas like this



WORK AT HEIGHT



Covered openings



Railings used to fence off hazardous areas must be at least 1.1 m tall

- 4.2.9. When choosing the lanyards and possible anchor points, one must take the height that the worker can fall from into account. In order to choose the right lanyard, one must add the length of the lanyard to the length of the absorber (when engaged), the height of the worker, the safe clearance under the worker's feet (1 m) and the location of the anchor point relative to a stable surface. A lanyard and an anchor point are selected correctly if the total of these values is less than the elevation of the working surface.



WORK AT HEIGHT

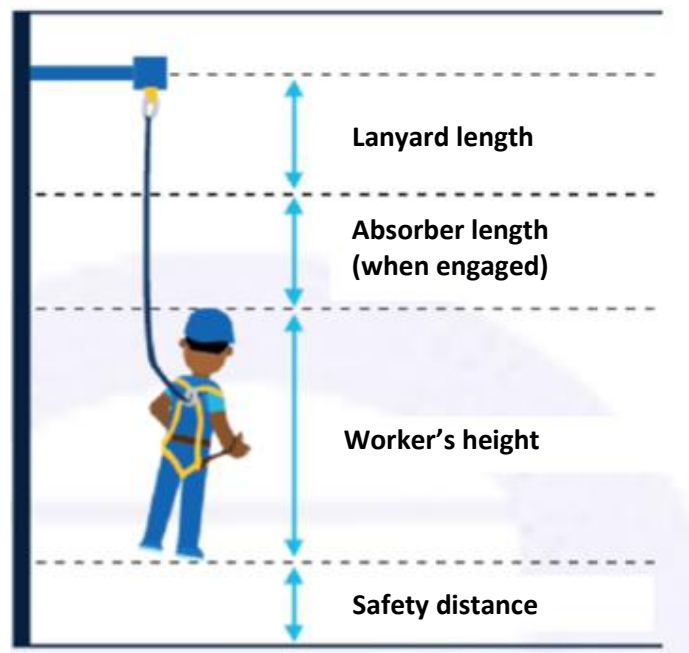

4.2.10. The higher the anchor point, the less clearance under the worker, in which there is no risk of coming into contact with parts of structures or other objects during the fall, resulting in injury for the user, meaning that it is safer.

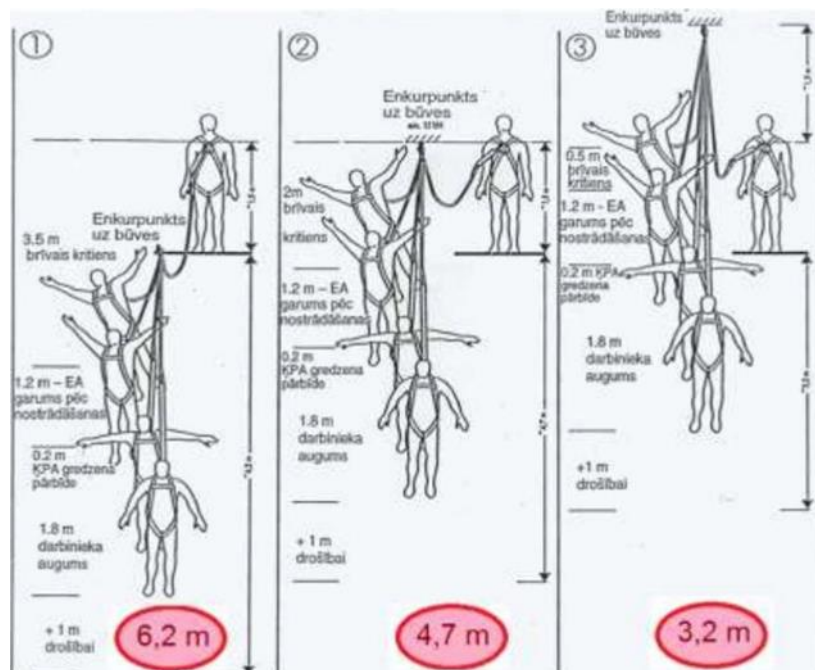

Required clearance under a person work at height, depending on the location of the anchor point

4.2.11. When working on a roof involves a limited number of anchor points, a “lifeline” or other safety measures may be set up for the workers to attach themselves or their personal protective equipment to, in order to ensure safe work.



WORK AT HEIGHT



The fall protection system is attached to the lifeline: a cable or a rope



THE BIGGER THE DISTANCE BETWEEN THE ANCHOR POINTS, THE MORE DEFLECTION IN THE EVENT OF A FALL

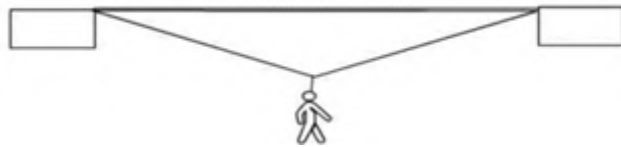

When setting up a rope, take its deformation value into account. For example, if under stress, the rope extends by 4%, it means that a 25-metre rope can become 1 metre longer

4.2.12. Work at height may only be performed by a team of at least 2 people.

4.2.13. When performing work at height on horizontal surfaces not equipped with collective protection fencing, workers must use positioning safety lanyards, the length of which is such that they prevent the worker from climbing over the edge.

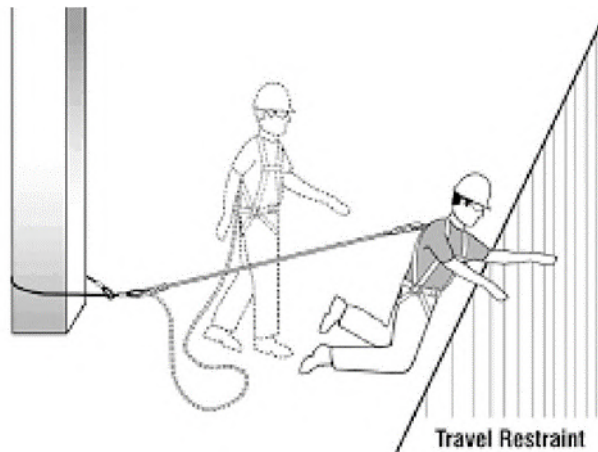

4.2.14. It is allowed not to use such lanyards if the worker does not have to perform their tasks less than 2 metres from the edge of the horizontal surface. In such situations, the work is not considered work at height.

4.2.15. The work area under the location where work at height takes place must be fenced off and provided with a warning sign:



WORK AT HEIGHT



4.2.16. If a fall occurs during work, and the workers of the contractor have lifted the victim up prior to the arrival of FRSS, the victim **must be put in a sitting position, with the knees bent at a 90-degree angle, for at least 20 minutes**, and only then laid down.

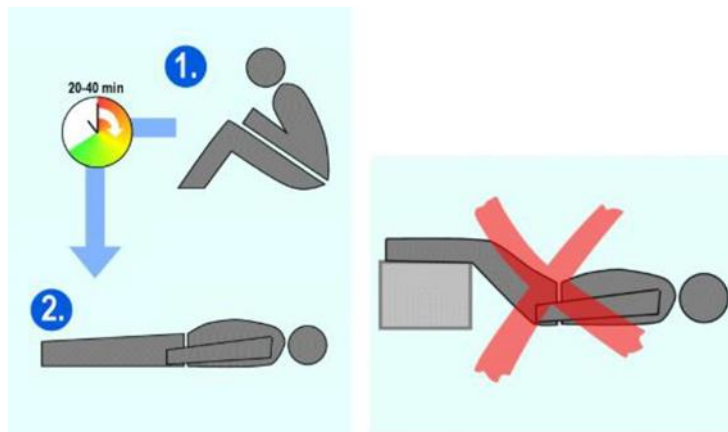



WORK ON SCAFFOLDING

4.3. Working on scaffolding

- 4.3.1. If scaffolding is assembled following their manufacturer's instructions and the requirements of applicable standards, working on it is not considered work at height.
- 4.3.2. Working on scaffolding is prohibited if the wind speed exceeds **15 m/s**.
- 4.3.3. Full assembly and disassembly of scaffolding is considered to be work at height, and the workers performing such tasks must always use all the necessary fall protection gear: a fall protection system with two lanyards attached to anchor points (load-bearing structures) on the scaffolding.
- 4.3.4. The assembly of scaffolding may only be performed by workers with appropriate training, under the supervision of the specialist in charge of scaffolding. The assembly plan must be kept by the worker in charge, or at the location where the scaffolding is set up.
- 4.3.5. The work area must be fenced off if the work area is near road and pedestrian traffic ways. The fencing must be such that it is visible in poor weather and low visibility conditions.
- 4.3.6. A warning sign must be installed on scaffolding and towers when assembling:



- 4.3.7. Scaffolding must be installed onto a flat base capable of withstanding the load, ensuring the stability of the scaffolding.



Scaffolding installed onto an unstable base



WORK ON SCAFFOLDING

4.3.8. There must be a way to approach and get onto the scaffolding, and it must be possible to move safely from one level of scaffolding to another.



Unsafe access and moving around scaffolding

4.3.9. Portable ladders may only be used for accessing scaffolding if the height involved is less than 5 metres, provided that the ladders are secured against slipping.

4.3.10. Scaffolding is assembled level-by-level: starting the assembly of the next level is only allowed if the current level is completed and fully equipped with all the parts it needs to be rigid, well-fastened, without hazardous openings; the disassembly of a level may only be carried out if the levels above it have been disassembled.

4.3.11. Scaffolding must be installed in accordance with the assembly instructions issued by the manufacturer, making sure that the following conditions are met (see figure below):

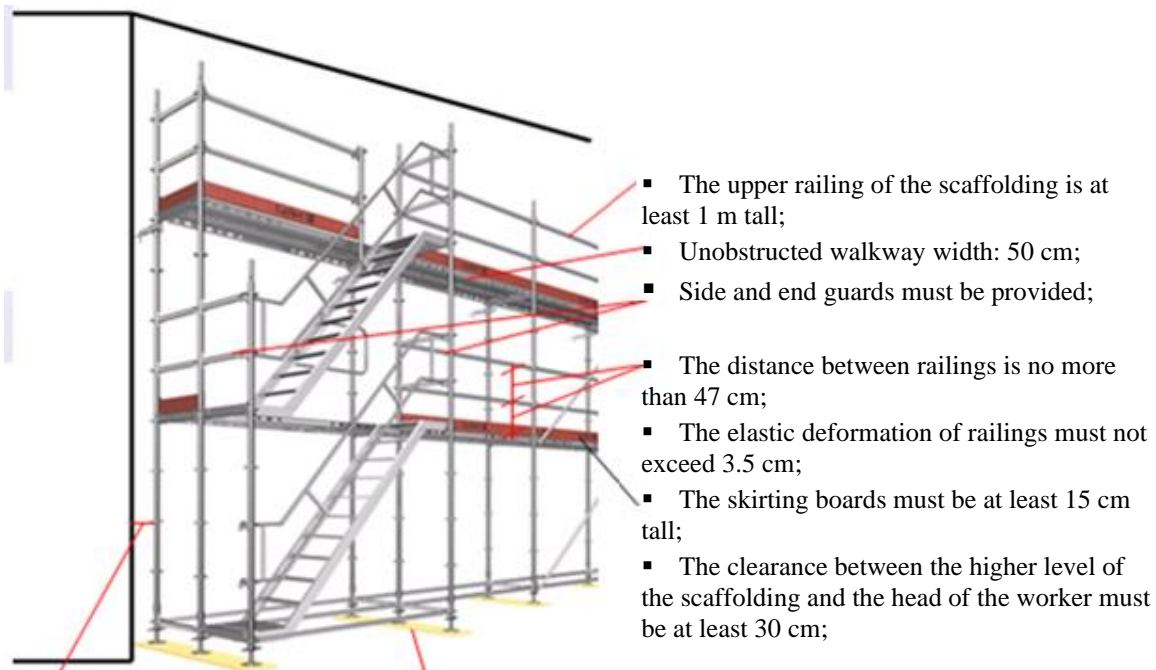

- The maximum distance between the wall of the building or other structure and the scaffolding is **30 cm**; otherwise, the scaffolding must be fenced off on both sides;

- The feet of scaffolding must be placed onto a secure base, to prevent it from sinking into the soil or tilting;

- The upper railing of the scaffolding is at least 1 m tall;
- Unobstructed walkway width: 50 cm;
- Side and end guards must be provided;
- The distance between railings is no more than 47 cm;
- The elastic deformation of railings must not exceed 3.5 cm;
- The skirting boards must be at least 15 cm tall;
- The clearance between the higher level of the scaffolding and the head of the worker must be at least 30 cm;



WORK ON SCAFFOLDING

4.3.12. Side supports must be used on towers. Using a tower is prohibited if the slope of the base surface exceeds 7 degrees.



Side supports installed on scaffolding, and there is a way to move safely from one level to another

4.3.13. Wheels must be blocked on scaffolding and towers with wheels.

4.3.14. Scaffolding must be attached to fixed and strong structures in the manner and using the fastening elements specified in the assembly plan for scaffolding.

4.3.15. When setting up a tower, its height to width ratio must not exceed 4:1 if installed indoors, and 3:1 if installed outdoors.

4.3.16. When moving a tower, its height must not exceed 3 metres.

4.3.17. Moving towers or scaffolding with workers, tools and materials on them is prohibited.

4.3.18. If the load-bearing structures (the frame) of the tower are used to climb onto the working level of the tower, then the climbing must be done from the inside of the tower. Climbing a tower on its outer side is **strictly prohibited**.

4.3.19. Once a tower or scaffolding is assembled, the worker in charge of it checks if the scaffolding is ready



WORK ON SCAFFOLDING

for use and prepares a certificate confirming this (in no particular form).



The worker in charge of operating the scaffolding must inspect its safety at least once a week and after poor weather, making an entry in the inspection log

4.3.20. The readiness of scaffolding for operation is confirmed by a signed placed at the access point to the scaffolding:



4.3.21. When walking on scaffolding and towers, workers must correctly place tools and heavy objects on them.

4.3.22. When moving between different levels of scaffolding, one must always close the hatch after climbing down or up.

4.3.23. Work platforms (surfaces) must be stable and flat/even.



Incorrectly prepared platform



WORKING ON PORTABLE LADDERS

4.4. Working on portable ladders

- 4.4.1. Ladders may only be used if the work cannot be performed with any other type of equipment, such as a fixed object, tower scaffolding, portable lighting work platforms etc.
- 4.4.2. The following conditions must be met when using ladders:
- 4.4.3. the ladder must be stable;
- 4.4.4. the ladder must be placed onto a sufficiently large supporting surface that does not move;
- 4.4.5. the work area must be fenced off if the work area is near road and pedestrian traffic ways. the fencing must be such that it is visible in poor weather and low visibility conditions;
- 4.4.6. the ladder must be secured against slipping, swaying or moving inadvertently;
- 4.4.7. the upper section of the ladder must be at least 1 m above the surface, which one is to climb onto;

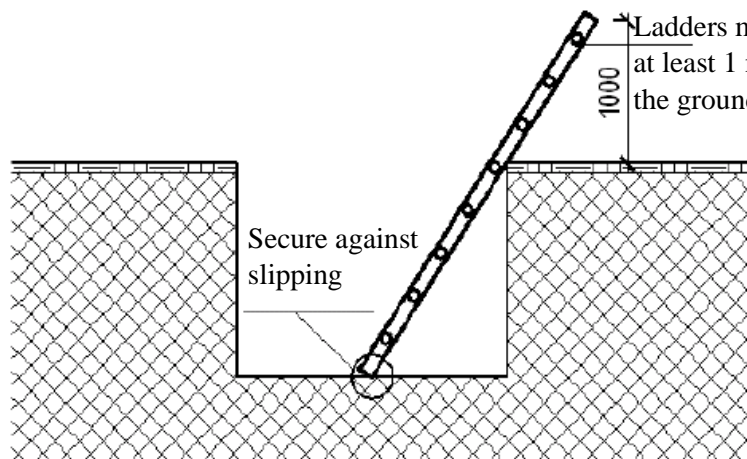

If the end of a ladder is not 1 metre above the surface of the ground, additional support must be provided that the workers can prop themselves against when climbing in or out of the trench/construction pit.



- 4.4.7.1. throwing any objects up to people working on ladders is prohibited;
- 4.4.7.2. when performing work on a ladder, climbing higher than the 3rd step, counting from the top, is prohibited;
- 4.4.7.3. the maximum work area for those working on ladders is within the reach of an outstretched hand, while both feet are on the step of the ladder;
- 4.4.7.4. when performing work on leaning, extending or suspended ladders at a height of more than 1.5 metres, and if both the hands are occupied, the worker must use a full-body fall protection system, with a lanyard connected to a strong anchor point;
- 4.4.7.5. only one person may be on a single ladder at any single time; each side of a twin ladder can accommodate one person at any single time.
- 4.4.7.6. working on ladders is only allowed if at a height of less than 5 metres, counting from the base to the step, on which the worker is standing, unless the ladder is equipped with a collective fall protection system and has stabilising supports;
- 4.4.7.7. a period of continuous work on a ladder may not exceed 30 minutes, after which the worker



WORKING ON PORTABLE LADDERS

must take a break to relieve the stressed parts of the body.

- 4.4.7.8. when carrying ladders, they must be held by the frame, such that the ladder is at an incline, with the front end being higher. One must be careful when turning;
- 4.4.7.9. two workers may carry a ladder with three sections, in a horizontal position, with the end pieces at the rear, warning any people walking in the opposite direction;
- 4.4.7.10. any manipulations with extensible three-section ladders, moving, setting up folded in a vertical position, extending and folding, may be done by two people. When working on portable ladders at a height of more than 1.5 m, the work must be done by two people: one performs the work, the other secures the ladder;
- 4.4.7.11. if work is carried out on a ladder, no work is allowed under it;

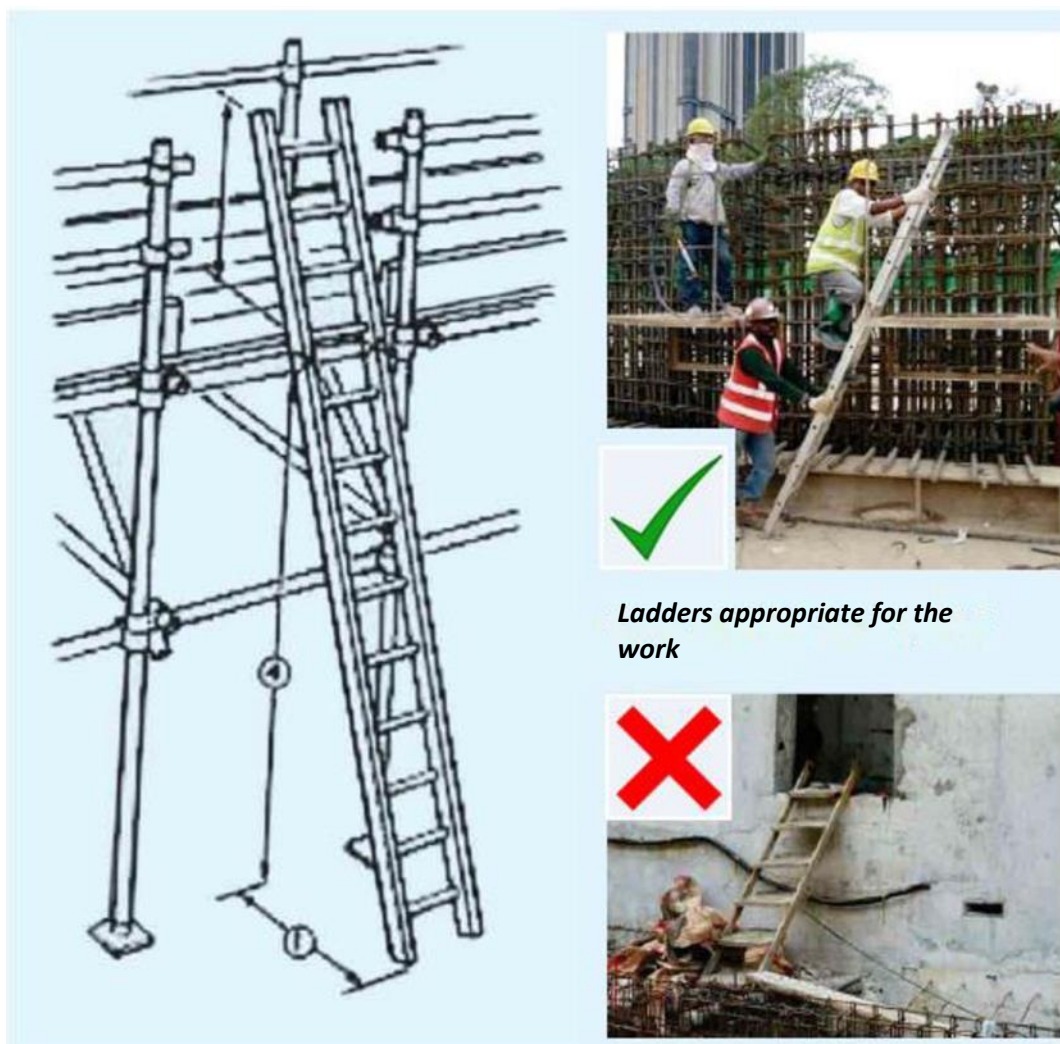

Ladders appropriate for the work

4.4.7.12. IT IS PROHIBITED:

- 4.4.2.17.1. to use ladders to lift or lower heavy objects;
- 4.4.2.17.2. to place tools and parts on the steps and the upper platform of the ladder;
- 4.4.2.17.3. to stand under the ladder if there is a worker on it;



WORKING ON PORTABLE LADDERS

- 4.4.2.17.4. to use twin ladders as single ladders, unless otherwise specified by the manufacturer;
- 4.4.2.17.5. to move the ladder if there is a worker on it.

- 4.4.7.13. to use a damaged or deformed ladder.



Damaged or deformed ladders have lost their strength and do not enable the safe movement of the worker

- 4.4.7.14. Restrictions and conditions for correct installation and operation of (folding) ladders:





WORKING ON PORTABLE LADDERS

4.4.7.15. When performing work on a ladder, workers must observe the following restrictions:



The workspace must be limited to the distance of an outstretched hand while both feet are on the step. You may have to move the ladder a number of times while performing a task.

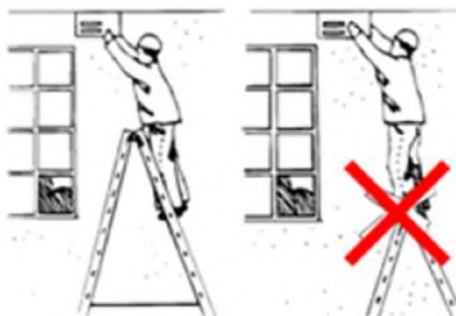

Do not climb higher than the 3rd step counting from the top



The ladder must be placed against the wall at a 60–70-degree angle

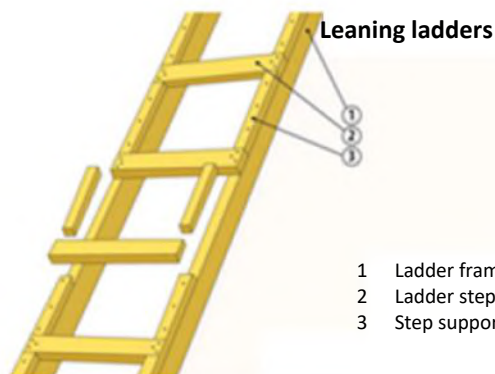

Leaning ladders

- 1 Ladder frame
- 2 Ladder step
- 3 Step support

If a ladder is made at the site, the manager in charge must prepare a certificate on the safe use of the ladder

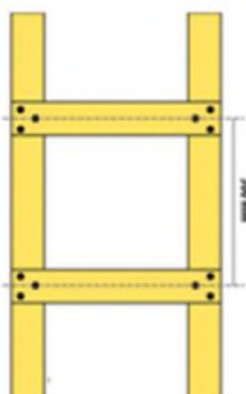

The length of crossbars and steps must be at least 280 mm;

The distance between the steps of the ladder must be even, between 250 and 300 mm.



WORKING WITH HIGH-PRESSURE DEVICES

4.5. Working with high-pressure devices and painting

- 4.5.1. A work order must be prepared for performing the work; see Section 3.2 for the procedure.
- 4.5.2. Pressure tanks must be provided with an information plate (at least 200x350 mm in size) attached in a well-visible location, containing the following details: the holder of the hazardous equipment, the BIR registration number, the date of the last and the next inspection. The maximum operating pressure must also be specified for pressure tanks.



Equipment information has been erased, preventing compliance with the requirement

- 4.5.3. VTL is entitled to task the Contractor with performing additional inspections on hazardous equipment that already underwent an inspection, extraordinary inspections if visual damage was found in the equipment, such oil leaks, broken hydraulics hoses etc.
- 4.5.4. All hoses intended for high pressure must be equipped with additional safety connections.



The hoses are equipped with an additional safety connection

- 4.5.5. Main line hoses (e.g. between the compressor and the pressure tank), as well as all electrical cables must be placed on racks. The racks must have no sharp ends and must be identifiable.
- 4.5.6. If the air intended for performing the work is also used **for those working in an environment unsuitable for breathing**, then a warning (sound or light) signal must be additionally installed on the machine, to be triggered whenever the compressor stops working; furthermore, measures must be taken to prevent the exhaust of an internal combustion engine being near the air intake of the compressor.



WORKING WITH HIGH-PRESSURE DEVICES



The device is equipped with a light indicator to signal its unexpected shutdown

- 4.5.7. If the air intended for work is also used by **workers in an environment unsuitable for breathing**, any water, oil, other chemicals or hard particles must be removed from it.
- 4.5.8. In order to ensure that the air is clean, the breathing air filter must be changed regularly, and at least as often as prescribed by the manufacturer of the filter (the service life is usually specified in hours worked, and for most filters it is 450 hours worked). To comply with this rule, the employer must keep track of the hours worked for the compressor (filter), and if necessary (or requested), present these records to VTL.
- 4.5.9. When performing tasks such as sand-blasting surfaces to clean them, or painting/priming them using high-pressure equipment, assess the possible spread of droplets of paint due to wind.
- 4.5.10. Information signs providing details about the work taking place and the potential risks associated with them must be placed at the outer boundary of the zone where wind can cause paint droplets to end up on property (e.g. buildings, vehicles), on the premises of VTL and beyond.



The information sign must be firmly attached and capable of withstanding weather



WORKING WITH HIGH-PRESSURE DEVICES



An information sign to warn people about the work taking place installed at the boundary of a potentially hazardous area

- 4.5.11. If painting work may result in paint droplets ending up on buildings or structures on the VTL premises, the Contractor must take measures to protect these buildings and structures prior to performing the work, for example, by covering them in film.
- 4.5.12. For the entire duration of the work, it must be ensured that the protective measures perform the function assigned to them, repairing and replacing them as necessary.



Windows covered in film to protect against paint droplets

- 4.5.13. Once the work is done, any auxiliary materials used to protect the building or machinery must be removed, so that the original condition of the buildings or machinery is restored.



MOVING CARGO

4.6. Moving cargo







FOLLOW THE CARGO LOADING AND MOVING PLAN

Moving cargo is high-risk work. It involves heavy loads, space, storage locations and other aspects, which is why a cargo moving plan is necessary. Regular work does not require a general plan. For moving non-standard cargo, including difficult and heavy cargo, one must prepare a specialised plan, a task that must be performed by a competent manager or persons responsible experienced in moving cargo.

- Understand the plan for moving cargo before beginning the work, and then follow it.
- Make sure that the stress created by the cargo does not exceed the capacity of the lifting gear or auxiliary equipment.
- Make sure that the crane is levelled and is on a hard base.
- Check if the equipment to be used to move cargo has been installed and is in good working order.
- Fence the cargo moving area off. Make sure that third parties cannot enter that area. Use barriers and clearly visible warning signs.





DO NOT WALK OR STAND UNDER LIFTED LOADS

- When assessing the situation around you, look up to make sure that there is no load lifted above you.
- A lifted load is an object that is hoisted for a certain time and hangs above the ground.
- Moving or being under a lifted load is not safe: it can fall onto you.
- The likelihood of evading a falling object is minimal.
- Never enter a fenced-off work area if you are not involved in moving cargo.
- Observe the instructions, signs and signals of the cargo moving operator.

4.6.1. The employees of the contractor involved in the moving and slinging of cargo must undergo external training at least once every 5 years, in a licensed training facility.



4.6.2. Any cargo loading and moving work must be performed in accordance with the cargo loading plan. A sample loading plan form is enclosed with these guidelines.



MOVING CARGO

- 4.6.3. Any machinery and gear (straps, hooks, chains) used to load or move cargo must be inspected. The responsible VTL representative is entitled to request documentation for the inspections carried out from the Contractor. Inspections must take place as follows:
 - 4.6.3.1. An external inspection of all rigging equipment that is a part of the hazardous equipment must be carried out at least once every 12 months.
 - 4.6.3.2. An internal inspection of all other rigging equipment and gear must be performed at least once every 12 months.
 - 4.6.3.3. It is prohibited to use synthetic straps that have been used for more than 5 years since the date of production specified by the manufacturer, regardless of the technical condition of the straps.
- 4.6.4. Equipment used for lifting must have clear and legible specifications values on it.



- 4.6.5. If such information is illegible or completely absent from a synthetic strap, **use of such a strap is prohibited**, regardless of its age or visual condition, except for in the following cases:
 - 4.6.5.1. New synthetic straps in packaging with an expired use-by date;
 - 4.6.5.2. New (visually) straps without markings;
 - 4.6.5.3. In these cases, the straps must be checked, and a certificate must be prepared and signed by a commission comprising a person trained in the identification, inspection, storage and use of straps.
- 4.6.6. Loading and moving of cargo may only be performed if the wind speed does not exceed 15 m/sec (including gusts of wind).
- 4.6.7. When setting up lifting machinery and mechanisms, one must be keeping the composition of the soil and the distance from the edge of any slopes in mind.

Minimum distances from slope, trench and construction pit edges (if not reinforced) for lifts

Trench depth, m	Distance* from the beginning of the slope to the nearest outrigger, depending on the soil (undisturbed), m				
	sand	sandy loam	clayey sand	clay	dry loess
1	1.50	1.25	1.00	1.00	1.00
2	3.00	2.40	2.00	1.50	2.00
3	4.00	3.60	3.25	1.75	2.50
4	5.00	4.40	4.00	3.00	3.00
5	6.00	5.30	4.75	3.50	3.50

* The distance is measured from the upper vertex of the trapezoid in the cross-section of the trench or construction pit.



MOVING CARGO

- 4.6.8. Make sure that the characteristics of the lifting machinery or gear (e.g. lifting capacity at a certain distance, maximum amount of cargo that can be lifted) and the function of the special vehicle or machine makes it possible to safely move or lift cargo.
- 4.6.9. The lifting machinery or special vehicle must be appropriately prepared prior to work: due measures must be taken to prevent the machinery from tilting, tipping over, moving or sliding. **Outriggers without additional supports must not be placed on top of utility infrastructure.**





MOVING CARGO



Planks are not a suitable and stable base for the outriggers of a lifting machine

4.6.10. If the lifting machine is not equipped with standard outrigger supports, then outriggers may be fastened using plates made out of a material appropriate for the parameters of the lifting machine.



Metal plates put under all of the outriggers of a lifting machine

4.6.11. The area for loading and moving cargo must be adequately lit.

4.6.12. The contractor appoints the workers in charge of safely moving cargo at the work area.



MOVING CARGO

4.6.13. The person in charge of safely moving cargo must provide the other workers with information (explanations) about the work task and additional safety requirements that must be met during the work, for example signals for communication.

4.6.14. Employees involved in the loading of cargo must wear a reflective vest, as per EN 471.



4.6.15. The area where loading takes place must be fenced off.



The area used for moving cargo is fenced off, and warning signs are set up

4.6.16. The dangerous area in the cargo moving area is determined based on the following data

H (m)	Up to 10	From 10 to 20	From 20 to 70
L (m)	4	7	10

Where: H – cargo lifting height, m;

L – Dangerous area from the edge of the maximum volume of the cargo, m.

4.6.17. Before use, the strap must be checked visually to confirm that it has no damage (worn out areas, torn threads, broken, knotted, folded otherwise damaged straps), including damage that is not visible due to deposits, but that can affect the safety of using the strap, and straps that did not undergo regular inspections within the time specified (at least once a year, or as prescribed by the manufacturer). The strap must meet the specifications and must be identifiable based on its markings.



MOVING CARGO

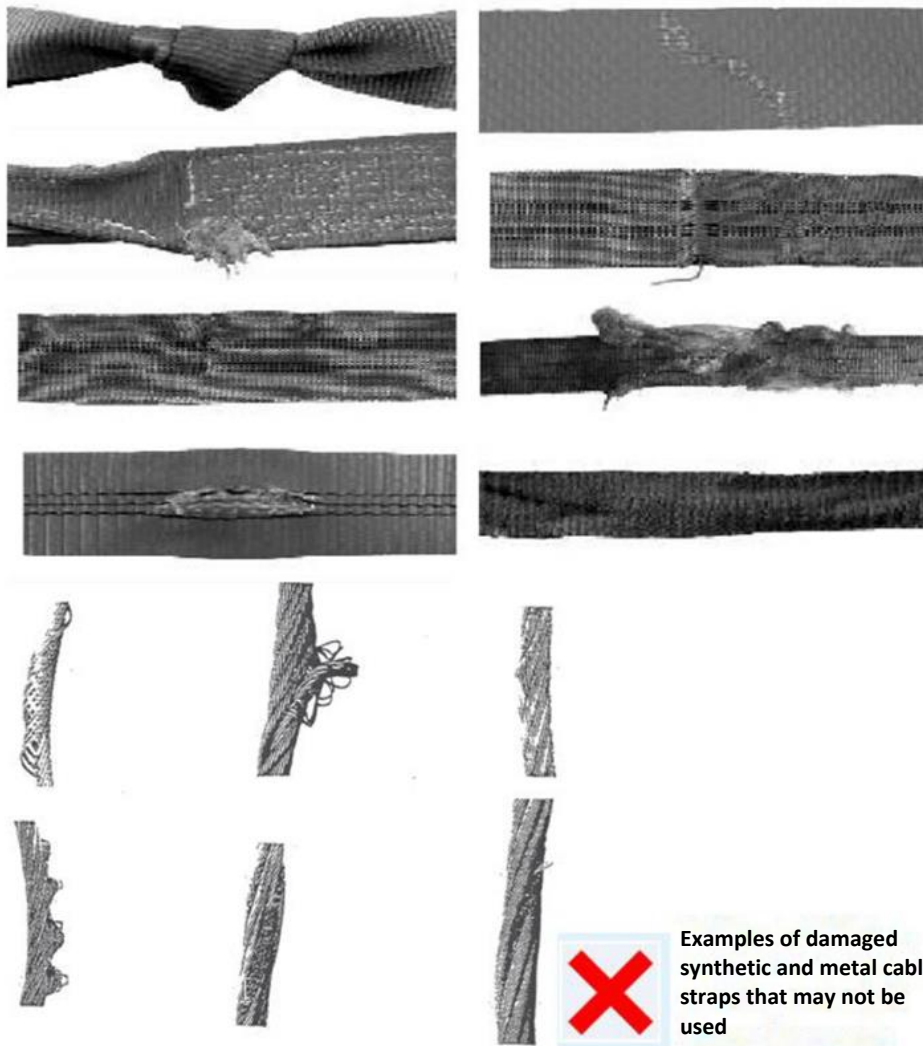

4.6.18. The Contractor must correctly store the straps.



4.6.19. Loading and unloading must be planned in advance; if necessary, if the trajectory of the movement of cargo is not sufficiently predictable, a signalling worker must be appointed to use certain signals to give instructions to the operator of the lifting machine and take appropriate measures to prevent loads from colliding and eliminate risks to the health and safety of those working nearby.



MOVING CARGO

- 4.6.20. It is only allowed to move cargo, the weight of which does not exceed the capacity of the lifting machine, the straps or other lifting gear. For moving small single piece cargo use appropriate containers filled up to no less than 10 cm from the upper edge of the container.
- 4.6.21. When lifting cargo, the cables of the lifting mechanism must be in a vertical position (it is not allowed to pull up cargo that is in a sideways position). The load must first be lifted no more than 0.2–0.3 m and briefly kept at that height to confirm that hooking and slinging is performed correctly, and check the stability of the lifting mechanism and the operation of the brakes.
- 4.6.22. When moving cargo, make sure that there are no workers near it and in the area where the cargo is to be put down; do not be there yourself.
- 4.6.23. The cargo must be placed and distributed in a uniform manner, observing the dimensions set for unloading the cargo, without obstructing any road and pedestrian traffic ways. The distance between the piles must be at least 1 metre.
- 4.6.24. When placing loads next to trenches, construction pits etc., the distance from the edge must be no less than 1 metre to the possible break line or reinforcement to prevent a collapse.
- 4.6.25. It is not allowed to:
 - 4.6.25.1. relocate or remove cargo gripping gear after the cargo is placed securely and, if necessary, fastened;
 - 4.6.25.2. stand under a lifting machine or its boom that moves cargo, using hazardous and narrow spaces created by moving cargo to prevent being crushed between the cargo, various structures, the boom and machinery, and make sure that the cargo does not move above people and cannot catch onto anything;
 - 4.6.25.3. pull a load along the ground, floor, rails etc. pull at the cargo during its lifting, moving or lowering while the hook of the lifting machine, the cables or straps of the cargo are in a slanted position;
 - 4.6.25.4. place a load onto temporary ceiling/flooring, pipes, cables and in other areas not intended for this purpose;
 - 4.6.25.5. prop a placed load against walls, columns or piles;
 - 4.6.25.6. bring cargo in through door and window openings if there are no special platforms or other devices for receiving it;
 - 4.6.25.7. use the hook of a lifting machine or special vehicle to pull out straps, cables or chains crushed under cargo;
 - 4.6.25.8. move, transport, lift cargo using special vehicles and machinery not intended for that purpose;
 - 4.6.25.9. load or unload a vehicle if there are workers inside its trailer or cab, unless the cargo is not transported above the cab of the vehicle, and the worker handling the straps can keep a safe distance from the cargo, or go onto a safety platform;
 - 4.6.25.10. attach cargo that is buried in soil, frozen to the ground or that is otherwise not moving freely (as well as jammed cables, ropes, straps, chains) to the hook of a lifting machine;
 - 4.6.25.11. leave the machine with a lifted load unsupervised;



MOVING CARGO

4.6.25.12. be under a lifted load, the boom of a lifting machine, and on top of a load, and allow other people to be under/on top of a load.

4.6.26. Lifting gear must be correctly used during loading.





MOVING CARGO

4.6.27. Use the principles of safe slinging when lifting cargo.

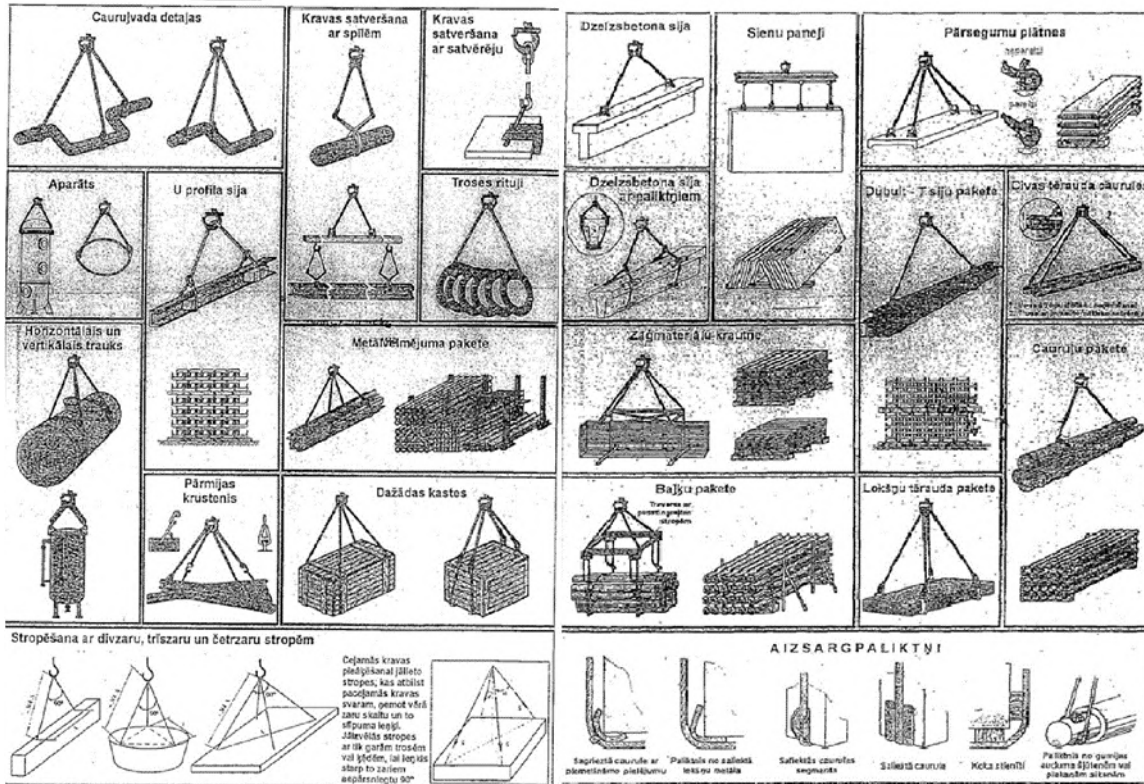

4.6.28. If when moving cargo, it can sway significantly, the cargo must be provided with safety ropes that workers can use to restrict the sway of the cargo from a safe distance.



Rope for reducing cargo sway



MOVING CARGO

- 4.6.29. Lifting machinery must be provided with the following information about their technical data (load capacity (t), last and next inspection date); the information must be legible and applied in a clearly visible location:



Information with the characteristics of a machine is placed on it in a visible location.

- 4.6.30. The VTL safety coordinator is entitled to require the Contractor to perform repeated certification of a hazardous machine if there are reasonable concerns as to its technical condition, regardless of how long is left before the last inspection expires.
- 4.6.31. The minimum distance between the lifting machine and nearby machines or structures must be at least 600 mm (0.6 m).

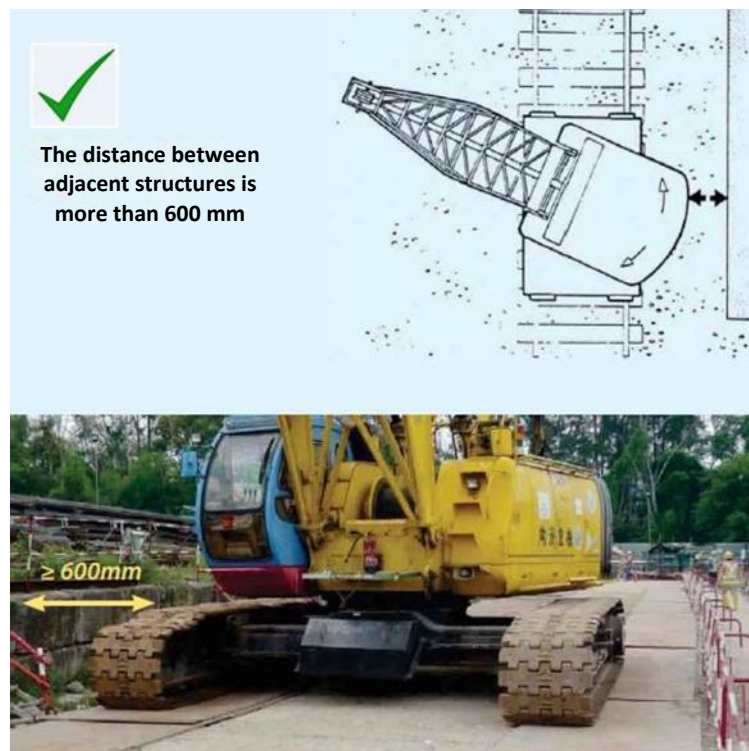

- 4.6.32. If it is necessary to move cargo that can create a high level of risk to other people (e.g. if the object projects out of the vehicle), FRSS must be informed of this, and the cargo must be moved under the supervision of an FRSS officer.



WORKING WITH AERIAL LIFTS INTENDED FOR LIFTING PEOPLE

4.7. Working with aerial lifts intended for lifting people

4.7.1. Aerial lifts intended for lifting people by more than 3 metres are classified as hazardous machinery that must be duly inspected and registered.



1. BIR number;
2. Person in charge of using the machine;
3. Lifting capacity;
4. Maximum elevation;
5. Maximum permitted wind speed.

4.7.2. The employees of the Contractor that perform work using an aerial lift must undergo external training for work with an aerial lift at least once every 5 years, in a licensed training facility.

4.7.3. The VTL safety coordinator is entitled to require the Contractor to perform repeated certification of a hazardous machine if there are reasonable concerns as to its technical condition, regardless of how long is left before the last inspection expires.

4.7.4. An aerial lift may only be operated by properly trained employees who have an appropriate qualification certificate. The VTL person in charge may require the Contractor to present the certificate confirming the operator's qualification.

4.7.5. See 'Moving cargo' section for instructions on placing an aerial lift and fencing it off.



Work area of an aerial lift not fenced off



4.7.6. People working on the platform must agree with the operator of the aerial lift on the signals for mutual communication.

4.7.7. People working on the platform must use a full-body fall protection harness attached with a lanyard to **the spots specifically marked on the platform** (anchor points or load-bearing structure).

4.7.8. When moving the boom with the platform upwards, it must first be raised by no more than 0.5 m and held briefly to check if the lift is stable and the hydraulics system is operational.

4.7.9. When moving (turning) the boom with the platform horizontally, it must first be raised at least 0.5 m over any equipment, piles of materials and similar obstacles located within the trajectory of the



WORKING WITH AERIAL LIFTS INTENDED FOR LIFTING PEOPLE

move.

- 4.7.10. The operator must be at the operating panel throughout the duration of the work;
- 4.7.11. During the entire work, the operator must maintain continuous communication with the workers on the platform, keeping in mind the fact that if the platform is raised to a height of:
 - 4.7.11.1. up to 10 metres: direct verbal communication must be used;
 - 4.7.11.2. more than 10 metres: hand signals must be used;
 - 4.7.11.3. more than 22 metres: radio or telephone communication must be used.
- 4.7.12. It must be ensured that there are no unauthorised individuals that are not directly associated with the work being performed within the work area of the aerial lift.
- 4.7.13. The lift must be moved such that it does not come closer than 5 m from any live cables or wires, supports, fastening elements or working machinery.
- 4.7.14. Before lowering the platform, the operator must receive an affirmative signal to do so from a worker on the platform, or from a signaller (if there is one appointed), and then lower the platform in compliance with the safety measures.
- 4.7.15. The lift is intended for moving people, tools and materials (that are necessary for performing the work and do not exceed the operating parameters of the platform), and for performing work, including fire-fighting and rescue work at height.
- 4.7.16. It is prohibited:
 - 4.7.16.1. to use an aerial lift in any way it is not intended for, such as lifting loads (i.e. using them as a crane), lifting flammable or explosive substances, overloading the lift etc.;
 - 4.7.16.2. to set up a lift on unprepared soil and in areas with a slope that exceeds the value provided in the specifications for the lift. It is not allowed to place the outriggers of a lift on utility manhole covers, pavement kerbs, on ice and frozen puddles and other unstable and uneven surfaces;
 - 4.7.16.3. to operate the mechanisms of the lift if there are people on the boom, its mechanisms or in another potentially hazardous area;
 - 4.7.16.4. to move the entire lift with the boom raised and people on the platform, unless this is required by the operating manual for the lift;
 - 4.7.16.5. to leave the boom with the platform raised during breaks;
 - 4.7.16.6. to let people not directly associated with the work being performed within the reach of the boom;
 - 4.7.16.7. for workers on the platform to sit on/climb onto or over the railings, to use any additional ways to expand the operating area of the lift. Climbing off the platform is only allowed once it is placed onto a stable surface;
 - 4.7.16.8. to prop the platform against walls, supports or auxiliary structures;
 - 4.7.16.9. to pull the platform towards oneself using hands, or push it away from nearby structures;
 - 4.7.16.10. to use damaged accessories and containers;
 - 4.7.16.11. to throw work equipment, accessories and other objects off the platform;



WORKING WITH AERIAL LIFTS INTENDED FOR LIFTING PEOPLE

- 4.7.16.12. to rock the platform;
- 4.7.16.13. to climb or jump off the platform while it is in motion.
- 4.7.17. Whenever the platform moves and when performing work on the platform, the entrance into it must be shut and locked;
- 4.7.18. Any and all tools that can fall off during work (e.g. chainsaws, battery-powered angle grinders) must be prevented from falling;
- 4.7.19. If the operating area of the lift is not visible from where the operator control panel is, and the operator and the worker on the platform do not have the equipment to communicate with each other, a signaller must be assigned to manage any movements;
- 4.7.20. The signaller must comply with the following requirements:
 - 4.7.20.1. they must have sufficient command of the language, so that they can correctly understand any comments or instructions and follow them, ensuring safety;
 - 4.7.20.2. they know the meaning of verbal communication and hand signals; the recommended communication signals are enclosed with these guidelines;
 - 4.7.20.3. they must supervise all movements of the lift and take care of their own safety.
- 4.7.21. When working with a chainsaw, only one person is allowed to work on a platform.



WORKING WITH SPECIAL MACHINERY

4.8. Working with special vehicles

- 4.8.1. It is only allowed to use special vehicles (e.g. tractors, excavators, lorries) that have undergone the national technical inspection and that are in good working order, e.g. there are no fuel or oil leaks.
- 4.8.2. Special vehicles that run the risk of oil leaks (e.g. from the hydraulics system) must be equipped with an absorbent material and a container, in order to be able to quickly eliminate any pollution in the event of a leak.
- 4.8.3. If an oil or fuel leak is found in a special vehicle, the vehicle must be immediately shut down, and the pollution must be eliminated.
- 4.8.4. There must be at least 10 kg of absorbent material available in working areas where special vehicles are used.
- 4.8.5. Permanent roads or temporary roads approved in the work execution plan may be used for driving special vehicles in such a way that does not damage the infrastructure of VTL.
- 4.8.6. When leaving a site in a special vehicle, it must be ensured that it does not scatter any soil from the site over the road.
- 4.8.7. It is not allowed to conduct any special machinery corrections or repairs on the premises of VTL, except for the premises of the VTL Transport Division (the garage). If a machine cannot be delivered to a repair facility, the repairs may be performed on-site, subject to prior approval of FRSS and the VTL project manager.
- 4.8.8. If there are people working in the work area of the special vehicle, give off a sound signal to warn them of the vehicle moving. If the special vehicle is not equipped with a sound signal device, a signalling worker must be additionally assigned to coordinate the work and ensure that any people working nearby do not enter the work area of the special vehicle.
- 4.8.9. The driver must use a safety belt if the machine is equipped with it.
- 4.8.10. It is prohibited to use a machine to transport passengers if it is not intended for this purpose.



TOPOGRAPHIC WORK

4.9. Topographic work

4.9.1. Topographic work may be performed within the operational zone, provided that:

- 4.9.1.1. a corresponding PTW has been issued. No PTW is necessary if the work is carried out in the “green” zone;
- 4.9.1.2. the Contractor’s employee is provided with and uses a personal air quality analyser if the topographic work involves the use of electric equipment, including battery-powered equipment.





4.10. Sampling

- 4.10.1. In order to perform sampling, the Contractor's employee must receive a permit from the Operations Shift Leader.
- 4.10.2. The Contractor's employees that perform sampling must wear clothes made out of a fire-resistant fabric in accordance with EN 11612.
- 4.10.3. If an employee of the Contractor is to take samples from a tank containing products with a high content of benzene (this is indicated by a special sign at the ladder on the tank, or reported by the Operations Shift Leader), or other toxic substances, the employee must use a chemical protection suit and a full face mask with ABE filters, or filters specifically designed for the substance in question.
- 4.10.4. The following rules must be followed when taking samples from a tank or a tank wagon:
 - 4.10.4.1. when opening the hatches for measuring the level of oil products, one must stand upwind from the open hatch
 - 4.10.4.2. when measuring the level of oil products, and when opening a hatch, one must not look into the hatch or bring their face close to it, to prevent poisoning by the fumes.



Possible gas poisoning



- 4.10.4.3. once the level is measured or the samples are taken, all the tools used, the measuring hatch, the work platform must be carefully cleaned; the hatch cover must be closed and tightened with screws, preventing it from falling or banging against the edge of the opening. Any accidental spills of oil products next to the hatch must be immediately collected; the area affected must be properly wiped. It is prohibited to leave any wiping cloth, other materials or tools on top of a tank.



An accidental oil product spill is being collected



SAMPLING

- 4.10.5. **IT IS STRICTLY PROHIBITED** to take oil or oil product samples during the filling or draining of tanks. Sampling may be performed at least **15 minutes** after the filling or draining operation is over.
- 4.10.6. All operations associated with sampling that take place on top of a tank must be done within the fencing provided.
- 4.10.7. Empty bottles and bottles with oil product samples must be carried in special bags or boxes.



Special bag for transporting oil product samples

- 4.10.8. If the fittings of a tank or pipeline are frozen, then it is only allowed to use hot water or steam to heat them.
- 4.10.9. Samples from tank wagons and recipients/vessels may only be taken using special sampling devices (ATEX), or sampling devices made out of a material that cannot create mechanical sparking in contact with metal (as confirmed by a certificate), and provided with a conductive grounding cable or an antistatic rope made out of a natural material (the compliance of which is confirmed with a certificate for the material, which the Contractor must present to the VTL person in charge, if requested to do so. The rope must be tightly attached to the sampling vessel and grounded.



The tools and materials used to take samples must be made out of a non-sparking material

- 4.10.10. When taking samples from a tank wagon, the worker must use a fall protection system.
- 4.10.11. Taking samples and approaching tanks and tank wagons is prohibited during thunderstorms, and if the wind speed exceeds 15 m/s (on top of tanks) or 21 m/s (on overhead structures).
- 4.10.12. During the sampling process or when taking measurements, the contractor must ensure that at least two employees are present.



- 4.10.13. If it is not possible to meet the requirement mentioned in Paragraph 4.10.12, the employee must first report to the VTL Operational Shift Leader before going to the site and inform them about the specific tanks from which samples will be taken or measurements carried out. Upon receiving this information, the Operational Shift Leader will provide the contractor with a radio for communication purposes.
- 4.10.14. The contractor's employee must inform the Operational Shift Leader via radio in the following situations:
- 4.10.14.1. When they arrive at the site;
 - 4.10.14.2. When they have taken the sample (or completed the measurement);
 - 4.10.14.3. When leaving the site.
- 4.10.15. This communication is necessary to ensure the Operational Shift Leader is aware of the employee's status and knows where to send emergency services if the employee fails to establish communication.
- 4.10.16. Upon completing the work, the contractor's employee must return the radio to the VTL Operational Shift Leader.



4.11. Removal of asbestos or asbestos-containing materials

4.11.1. Asbestos fibres are very fine and not visible to the naked eye, and the finer the asbestos fibre, the more hazardous it is to the worker's health. Asbestos is a carcinogenic substance.



4.11.2. When performing work on the premises of VTL, the employees of the Contractor may come into contact with asbestos and asbestos-containing materials when conducting the removal of asbestos roofing, heat insulation, electric cable insulation, asbestos seals, asbestos-containing rainwater and industrial sewer pipes and telecommunications ducts.

4.11.3. The company keeps an inventory of asbestos and asbestos-containing materials, with a plan for removing such materials. The document identified the actual and possible locations of asbestos or asbestos-containing materials. The inventory records and the removal plan has been submitted and registered by the State Labour Inspectorate.

4.11.4. Basic safety requirements for removing asbestos or asbestos-containing materials:

4.11.4.1. Before starting the work, the manager in charge of it must conduct a target briefing on the hazards posed by asbestos or asbestos-containing materials, and on the safe work methods;

4.11.4.2. The employees of the Contractor who perform the removal of asbestos must undergo a mandatory medical examination, in accordance with the effective laws and regulations, specifically those governing asbestos;

4.11.4.3. When removing asbestos or asbestos-containing materials, the employees of the Contractor must use a disposable single-use protective suit, fully sealed protective goggles, rubber gloves, rubber boots, half-face masks with type P3 filters, or P3 no-maintenance respirators.

4.11.5. Asbestos or asbestos-containing material must be removed and disposed of as undamaged as possible; if prior to the removal, it is found that the asbestos-containing material is dry and the occurrence of dust during work is possible, the material must be moistened to minimise the spread of asbestos dust/fibre in the air.

4.11.6. The removal of asbestos-containing materials and the removal of asbestos residue from surfaces must be done using hand tools (e.g. chisels, scrapers), because they create less dust than power tools. Power tools may be used provided that the tools are set to the lowest speed, and additional methods to limit the spread of dust are used, such as moistening the material, using foam, or suctioning the dust away. **Cutting asbestos-containing materials with power tools is prohibited!**



- 4.11.7. The work must take place in a methodical manner: any material removed must be packaged into the (double) bags or containers intended for asbestos materials. The work must be performed consistently from top to bottom, to prevent any clean surfaces for being polluted again (e.g. the ceiling and the beams first, the floor last).
- 4.11.8. Any screws and nails must be carefully removed from plates and panels containing asbestos, so that no dust is produced. Any screws and nails thus pulled out must be treated as asbestos-containing materials.
- 4.11.9. If a large amount of dust arises during work, industrial vacuum cleaners must be used for additional dust removal, equipped with a class H filter for harmful dust (asbestos).
- 4.11.10. If a surface cannot be moistened and it is impossible to limit the amount of fibres in the air at the place where the work is taking place, the asbestos-containing material must be wrapped in polyethylene film, and then removed using the 'wrap and cut' method. In such cases it is recommended to use a glove bag, by placing it in an area where the separation of asbestos fibres during the removal of asbestos-containing materials is possible.



- 4.11.11. A glove bag may only be used once, and then discarded along with asbestos-containing waste.
- 4.11.12. The glove bag provides the worker with some protection that is, however, not sufficient, because of the possibility of inadvertently damaging the bag, which is why the personal protective equipment specified in Section 4.11.4.3 must be worn when using this method during work.
- 4.11.13. Asbestos-containing materials must be stored and transported in sealed packaging that prevents asbestos dust and fibre from getting into the environment. A sticker is applied to the packaging, warning of the presence of asbestos-containing materials in the packaging. The sticker must be 5 cm high and 2.5 cm wide.



- 4.11.14. The waste bags **MUST NOT** be filled more than partially, and their content must be wet. The bags must be closed carefully to prevent any excess of air in them. When putting waste into the bags, make sure that the shape of the bag does not result in any sharp corners or protrusions that could produce tears in the bag or packaging.



ASBESTOS

- 4.11.15. **Any gloves, no-maintenance respirators, disposable protective suits must be disposed of as hazardous waste along with asbestos or asbestos-containing materials. Boots, half-face masks must be rinsed under running water.**
- 4.11.16. Asbestos or asbestos-containing materials are disposed of as hazardous waste, by contracting a certified waste management organisation.



4.12. Pipelines

4.12.1. When performing work in the process zone, and specifically, in the areas where production infrastructure is set up, the Contractor must observe the following rules:

4.12.1.1. It is prohibited to drive vehicles over production pipelines unless the work methods and operating principles are approved by the VTL representative in charge.

4.12.2. When replacing, removing, installing or repairing pipelines and their supports, the corresponding section of the pipeline must be fastened with adjustable lifting jacks of appropriate load capacity and in sufficient quantity.

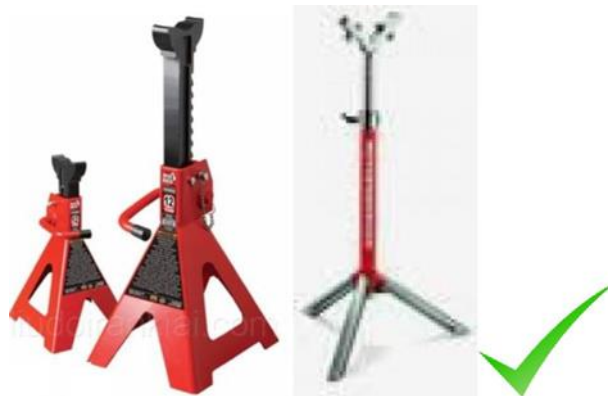

4.12.3. When performing work in a vehicle at a distance of less than 3 metres from production equipment (incl. pipeline), the Contractor must assign a worker as a signaller to monitor and ensure that the vehicle does not damage the production equipment or any other people working nearby.



SETTING UP WAREHOUSES, BUILDING AND FASTENING STACKS OF MATERIALS

4.13. Setting up warehouses, building and fastening stacks of materials

4.13.1. The location for setting up material warehouses must be approved during the development of the work execution plan, or by agreement with the VTL person in charge;

4.13.2. Requirements for material warehouses set up in containers:

4.13.2.1. maintain good order;



Untidy warehouse



4.13.2.2. storing flammable liquids together with combustible materials is prohibited;



Cans full of fuel are kept with combustible materials



4.13.2.3. storage areas for materials must not be used for keeping personal protective equipment.

4.13.3. Stacks of materials outdoors:

4.13.3.1. stacks must be set up such that they are stable, cannot tip over or injure those working at the site;



Stack of materials prevented from unforeseen movement



SETTING UP WAREHOUSES, BUILDING AND FASTENING STACKS OF MATERIALS

4.13.3.2. stacks must be fenced off to limit the workers walking next to them, if necessary;



Stack of materials separated to restrict the movement of workers next to it

4.13.3.3. any recovered materials must be put into stable stacks and not into disordered piles;



Inappropriate storage of materials

4.13.3.4. it is recommended to store materials (including recovered materials) separately based on their type: e.g. separating wood and metal etc.;

4.13.3.5. objects with open ends, such as pipes, must be provided with end covers until their installation, to prevent any soil, sand or other materials from accumulating in them;



Pipe ends provided with protection



4.14. Work near water



WHEN WORKING NEAR WATER, WEAR A LIFE JACKET



- A life jacket is required when working near water.
- If you are instructed to wear a life jacket, you must do so for the entire duration of the work that takes place near water.
- Before putting a life jacket on, make sure that it is in good working order and not damaged.
- Make sure that the life jacket is properly put on and fitted, and is of the right size.
- Do not work alone.

- 4.14.1. If the employee is required to work on the berths closer than 1 metre from the water, they must wear a full-body (four-point) fall-arrest harness and a life jacket (this work is considered as working at height). To facilitate compliance with this requirement, before starting the work, the contractor's work supervisor or the VTL project manager must contact the VTL HSEQ Department (labour protection specialist or process safety engineer), where the specialists will provide a special full-body fall-arrest harness with an integrated life jacket and conduct training.



WORK IN CONFINED SPACES

4.15. Work in confined spaces



GET A PERMIT BEFORE ENTERING A CONFINED SPACE

You are allowed to enter a **CONFINED SPACE**, which includes things such as tanks, construction pits if:



- The lockout/tagout (LOTO) procedure has been carried out on the appropriate machinery.
- A valid work permit has been issued.
- In accordance with the specifications of the permit to work, the confined space undergoes air quality testing.
- All the requirements specified in the work permit have been met.
- A person assigned to supervise entrance into the confined space is constantly there. Do not perform earthworks alone.
- There is a rescue plan that everybody understands.

4.15.1. A confined space is a partially or completely enclosed space:

- 4.15.1.1. from which it is difficult to get out;
- 4.15.1.2. that may have a narrowing in the walls or ceiling;
- 4.15.1.3. that has a sloping or conical floor;
- 4.15.1.4. which one may not be able to get out of.

4.15.2. On the premises of VTL, the most common places, working in which could be considered working in confined spaces are:

- 4.15.2.1. work in pits, including construction pits and trenches that are more than 1.5 m deep;
- 4.15.2.2. work inside tanks: above and under the pontoon, the space between the walls of a double-wall tank;
- 4.15.2.3. work in manifolds, in production, industrial and household sewer manholes;
- 4.15.2.4. closed reservoirs (e.g. fuel storage tanks in a fuel station);
- 4.15.2.5. tank wagons;
- 4.15.2.6. industrial wastewater pumping stations;
- 4.15.2.7. spaces under floor grilles in railway overhead structures;
- 4.15.2.8. spaces under floor grilles and other spaces in switchgear facilities.

4.15.3. Work may be performed in confined spaces if:

- 4.15.3.1. a general Permit to Work or a permit to work in confined spaces has been prepared;
- 4.15.3.2. the quality of air is inspected prior to the work, and the results are recorded in the permit to work in confined spaces;
- 4.15.3.3. the oxygen content is between 19.5% and 23.5%;
- 4.15.3.4. the visibility due to dust is no less than 1.5 metres;



WORK IN CONFINED SPACES

- 4.15.3.5. any flammable gases or fumes in the space do not exceed 10% of the lowest ignition value ('cold' work);
- 4.15.3.6. the air in the working environment does not exceed the maximum allowed operational exposure threshold value set for the chemical (acceptable level of exposure);
- 4.15.3.7. the space has ventilation, and an air exhaust;
- 4.15.3.8. all practical measures to ensure the safety of the workers who will enter the confined space to work have been taken: training, protective equipment etc.
- 4.15.4. If any of the criteria in 4.15.3.4 to 4.15.3.6 are not met (non-respiratory work environment), a task risk analysis (TRA) shall be carried out prior to entering the Confined Space with the aim of ensuring safety during the execution of the work.
- 4.15.5. The beginning of the work (no worker is yet in the confined space) and the end of the work (all of the workers have exited the space) in a confined space must be reported by the responsible worker to the responsible officer of FRSS, by calling: 636 66300.
- 4.15.6. Work in a confined space may only begin once the VTL FRSS person in charge checks the quality of air in the confined space. The quality of air is checked before work, and again, during the day, at the intervals specified in the work order.
- 4.15.7. Before entering a confined space, the worker must perform a last-minute risk analysis (LMRA), checking to make sure that all occupational risks are controlled and the work can be performed safely.
- 4.15.8. All employees in a confined space must be provided with air quality analysers. If issuing a gas analyser to every employee isn't possible, the foreman, in collaboration with the FRSS representative, shall assess the necessary quantity and usage details of the analysers, based on the results of the LMRA.
- 4.15.9. The air quality analysers must be capable of measuring the level of oxygen (O₂), the explosive hazard level (LEL), the hydrogen sulphide level (H₂S) in the air of the working space.
- 4.15.10. The air quality analysers are issued by the VTL FRSS person in charge.



Correctly attaching an air quality analyser to the clothing of a worker

- 4.15.11. Air quality analysers must be certified, calibrated and suitable for work in an explosive environment.



WORK IN CONFINED SPACES



Air quality analyser suited for working in an explosive environment (0, 1, 2) and at VTL

- 4.15.12. An entrance supervisor must be assigned when working in a confined space who:
 - 4.15.12.1. records all workers who enter or leave the confined space in the confined space permit;
 - 4.15.12.2. maintains communication with and monitors the people working in the confined space;
 - 4.15.12.3. Is located within 2 m of the entrance to the confined space;
 - 4.15.12.4. warns the workers within the confined space of any emergencies.



The entrance supervisor keeps track of workers and monitors the people working inside the confined space

- 4.15.13. Work in confined spaces may only be performed by those workers who have been familiarised with the occupational risks, who use the protective equipment specified in the work permit, and have been trained in how to behave in an emergency.



WORK IN CONFINED SPACES



- 4.15.14. Working in a confined space requires that the space be provided with ventilation. Before the ventilation is set up, its power and technical indicators must be approved by the responsible project representative of VTL.



The air supply system is set up correctly



WORK IN CONFINED SPACES



The clean air supply system is obstructed

- 4.15.15. Only one entrance/exit must be used for entering or exiting the confined space, so that the person supervising the entrance/exit can keep count of the workers. Any other exits in a confined space may only be used as emergency exits.



The same opening is used to enter and exit a confined space

- 4.15.16. If the air quality analyser is triggered, the worker must immediately stop their work and leave the confined space.



In the event of an emergency, the person supervising the entrance must not leave their post until all of the workers

- 4.15.17. Once the work ends, the confined space must be closed or fenced off using a barrier with a sign prohibiting people from entering the confined space.



WORK IN CONFINED SPACES



Setting up a barrier at an entrance to a confined space for a work break



Hazardous area left without supervision, with unrestricted access

- 4.15.18. It is prohibited to stay in confined spaces during work breaks, or leave tools, auxiliary materials, waste and other extraneous objects there.
- 4.15.19. No more than 6 people may work at any single time in a confined space
- 4.15.20. Every employee performing duties in the confined space shall be trained at least once a year as evidenced by a passing test score.



INTRODUCTION OF ADDITIVES

4.16. Introduction of additives

- 4.16.1. The company tasked with introducing additives must submit the lists of vehicles and the parties that use these vehicles to transport the additives in due time, preferably on business days, before 16:30.
- 4.16.2. **Two vehicles** transporting additives are allowed to enter the premises of VTL at any single time. The total amount of additives that may be kept on the premises of VTL must not exceed **50,000 kg**. Any additives beyond that amount must be kept at the car park located outside the fence surrounding the VTL site.



- 4.16.3. The company that performs the introduction of additives makes sure that any third parties hired to carry out the service are subject to the same safety requirements as those specified in these guidelines. **The company that performs the introduction of additives is RESPONSIBLE** for meeting this requirement.
- 4.16.4. **The company that performs the introduction of additives ensures that the work area provides easy access to safety data sheets for the chemicals, and that the workers are familiar with** the information provided in these safety data sheets, especially the sections covering the properties of the substance, the safety requirements, and the PPE. The safety data sheets must be kept in a metal cabinet marked with the sign:



- 4.16.5. If the additive station (while it is in operation) is visited by third-party workers, e.g. VTL employees during safety inspections, employees of the company that introduces additives, these workers must be informed of the possible hazards and risks associated with, for example, carcinogenic, poisonous substances, and of the safety requirements for coming into contact with these substances.
- 4.16.6. Any and all equipment (except batteries) used to introduce additives, such as pumps, electric motors, cables, electrical switchboards, lighting etc. must undergo technical maintenance/inspections, which must be acknowledged in an inspection certificate, or an internal



INTRODUCTION OF ADDITIVES

document by the holder of the equipment confirming that the equipment has been inspected and is safe. These inspections must be carried out within the time specified by the manufacturer of the machinery, and at least once a year.

- 4.16.7. Any hoses used to introduce additives must be made out of a material that is resistant to the product being fed.
- 4.16.8. All hoses must undergo electric resistance and hydraulic testing once a year. A certificate is prepared based on these tests, which the company must submit to VTL if requested to do so by VTL.
- 4.16.9. During the introduction of additives, it must be ensured that if an unauthorised spill occurs, the product does not get into the environment, that the pumps are located in the additive station, or that the vehicles carrying the additive are designed such that the product is kept in an enclosed container.
- 4.16.10. When introducing additives and whenever the vehicle is waiting on the premises of VTL, its wheels must be blocked with parking wedges (2 pcs).
- 4.16.11. When introducing additives, the tank or the tank container must be grounded.
- 4.16.12. If, in order to ensure the successful introduction of an additive, the worker must climb onto the tank or tank container, the worker must use safety systems preventing the risk of falling: a full-body fall protection harness with a positioning lanyard attached to the load-bearing structure.
- 4.16.13. To ensure prompt response in the event of a possible spill, various absorbent materials (covers, powder) are placed inside the Additive Station.



- 4.16.14. All waste contaminated with petroleum products and chemicals, such as absorbents, rags, etc., must be placed in a special container located outside the additive station.





INTRODUCTION OF ADDITIVES

- 4.16.15. Any electrical equipment, such as pumps with electric motors, portable distribution panels, and portable lighting equipment that is powered through cables (220V or 380V), **MUST BE INSPECTED** by the VTL Electrical Facilities Operation Engineer before use. They may only be used after receiving written (including email) approval.
- 4.16.16. All pumps intended for use in the additive injection process and provided by the contractor must be equipped with overpressure protection. Maximum pressures are specified in the procedure VTL-15.PR.020 “Additive Application Procedure”, which is mandatory for the contractor responsible for the additive injection.



CLEANING OF OPERATIONAL EQUIPMENT

4.17. Cleaning of operational equipment

- 4.17.1. In the context of these guidelines, production machinery is defined to include recipients/vessels, manholes (production and industrial sewer, household sewer, fire-fighting manholes, manholes), industrial sewer pumping stations, pipelines, manifolds.
- 4.17.2. The cleaning of production equipment such as recipients/vessels is considered to be work in an environment not suitable for breathing.
- 4.17.3. When cleaning tanks, one must always use systems that feed fresh air.
- 4.17.4. If a compressor is used to feed fresh air, it must be electric, to prevent any carbon monoxide from getting into the air supply system. If a different type of compressor is used a Task Risk Analysis must be performed.
- 4.17.5. If work is to be performed in an explosive environment and the equipment to be used (such as pumps, electrical switchboards, compressors) are not explosion-safe, then using such equipment is permissible provided that it is located at least 5 m away (in any direction) from the source of the possible explosive environment, such as the hatch of a tank or a drainage pit.
- 4.17.6. When using vacuum tanks for cleaning operational equipment, they must be placed at a distance of at least 5 m from the source of the explosive hazard, and the air exhaust hose of the tank must be placed such that its outlet is within the bunds at a distance of at least 10 m from the vacuum tank and the place where the equipment not designed for explosive environments is installed.
- 4.17.7. If the work is associated with the opening of the bund wall of a recipient, the work must be organised in such a way that the bund wall is not open, unless **the recipient is the only one inside the bund wall, it is empty**, and it is being prepared for repairs.
- 4.17.8. It is only allowed to open a bund wall for a brief time, e.g. to let vehicles in, to unload materials or to perform other quick tasks.
- 4.17.9. If vehicles are to spend a long time inside a bund wall, the bund wall must be closed (by pouring soil) once the vehicle enters.
- 4.17.10. Before commencing the cleaning (washing) of tanks in which petrol products have been stored, warning signs "CAUTION, EXPLOSIVE ENVIRONMENT. AUTHORISED ENTRY ONLY" are placed at the entrances of the bund wall. If such signs are not there, the foreman shall approach the VTL project manager to arrange for the signs to be placed
- 4.17.11. When the work is completed, the companies carrying out the tank cleaning (washing) shall inform the VTL project manager of the need to remove the signs "CAUTION, EXPLOSIVE ENVIRONMENT. AUTHORISED ENTRY ONLY".
- 4.17.12. Any and all equipment (except batteries) used to introduce additives, such as pumps, electric motors, cables, electrical switchboards, lighting etc. must undergo technical maintenance/inspections, which must be acknowledged in an inspection certificate, or an internal document by the holder of the equipment confirming that the equipment has been inspected and is safe. These inspections must be carried out within the time specified by the manufacturer of the machinery, and at least once a year.
- 4.17.13. When cleaning production equipment, the work must be carried out in such a way that no more than **30 minutes** are spent in an environment not suited for breathing, which must be followed by breaks or worker rotation.



CLEANING OF OPERATIONAL EQUIPMENT

- 4.17.14. When working in an environment not suited for breathing, the quality of air must be tested regularly once an hour; the readings of the air quality analyser must be recorded in the permit to work in a confined space. Measurement is performed by a trained employee of the Contractor.



TANK TRUCK FILLING/DISCHARGE

4.18. Tank truck filling/discharge

4.18.1. All vehicles transporting dangerous goods must be in good technical condition.

4.18.2. Only tank trucks and their semis that have a valid ADR compliance certificate can enter the territory of VTL. The validity of the certificate is confirmed by the date on it.

CERTIFICATE OF APPROVAL FOR VEHICLES CARRYING CERTAIN DANGEROUS GOODS!
ZULASSUNGSBESCHENKUNG FÜR FAHRZEUGE ZUR BEFÖRDERUNG BESTIMMTER GEFÄHRLICHER GÜTER
 (AE Reg 55-4)

This certificate testifies that the vehicle specified below fulfils the conditions prescribed by the European Agreement concerning the International Carriage of Dangerous Goods by Road (ADR).
 Mit dieser Bescheinigung wird bestätigt, dass das nachstehend bezeichnete Fahrzeug die Anforderungen des Europäischen Übereinkommens über die internationale Beförderung gefährlicher Güter auf der Straße (ADR) erfüllt.

1. Certificate number / Bescheinigung Nr.: _____ 2. Vehicle manufacturer / Fahrzeughersteller: _____ 3. Vehicle identification number / Fahrzeugkennzeichen: _____ 4. Registration number (if any) / evtl. Kasten-Plattennummer: _____

5. Name and business address of carrier, operator, or owner (Name und Betriebsadresse des Beförderers, Betreibers (Fahrzeug) oder Eigentümers): _____

6. Description of vehicle / Beschreibung des Fahrzeugs:

7. Vehicle designation according to 9.1.1.3 of ADR / Fahrzeugbezeichnung gemäß § 9.1.1.3 des ADR: _____ EXR _____ EXR _____ FL _____ AT _____ ME/M _____

8. End-use (Intending system) / Verwendungszweck:

not applicable / nicht zutreffend
 The effectiveness according to 9.2.3.1.2 of ADR is sufficient for a total mass of the transport unit of _____ kg
 Die Wirksamkeit gemäß 9.2.3.1.2 des ADR ist ausreichend für eine Gesamtmasse der Beförderungseinheit von _____ kg

9. Description of the tank (battery vehicle) (if any) / Beschreibung des (oder) Tank(s) (Batterie-Fahrzeug(s)) (wenn vorhanden): _____

9.1 Manufacturer of the tank: _____

9.2 Approval number of the tank(s) (battery vehicle): _____

9.3 Tank manufacturer's serial number/identification of elements of battery vehicle: _____

9.4 Year of manufacture / Baujahr: _____

9.5 Tank code according to 4.3.3.1 or 4.3.4.1 of ADR: _____
 Tankbezeichnung gemäß 4.3.3.1 oder 4.3.4.1 des ADR: _____

9.6 Special provisions T2 and T3 according to 4.8 of ADR (if applicable): _____
 Sondervorschriften T2 und T3 gemäß § 4.8 des ADR (falls zutreffend): _____

10. Designated goods authorized for carriage / Zur Beförderung zugelassene gefährliche Güter:
 The vehicle fulfils the conditions required for the carriage of dangerous goods assigned to the vehicle designation(s) in No. 7. Das Fahrzeug erfüllt die Anforderungen zur Beförderung gefährlicher Güter, die unter Nummer 7 angegeben / zugelassen sind.

10.1 In the case of an EXR or EXR vehicle / In Falle eines EXR- bzw. EXR-Fahrzeugs:

Class(es) of Class I including compatibility group 1
 Class(es) of Class I excluding compatibility group 1
 Class(es) of Class I excluding compatibility group 2
 Other as "A" class 1 assigned to compatibility group 2
 The substance specified under the tank code and any special provisions specified in No. 9 may be carried. (1)

10.2 In the case of tank vehicle(s) (battery vehicle) / In Falle eines Tank(s) (Batterie-Fahrzeug(s)):

The substance specified under the tank code and any special provisions specified in No. 9 may be carried. (1)
 The substance specified under the tank code and any special provisions specified in No. 9 may be carried. (1)
 The substance specified under the tank code and any special provisions specified in No. 9 may be carried. (1)
 The substance specified under the tank code and any special provisions specified in No. 9 may be carried. (1)

11. Remarks / Bemerkungen: _____

12. Valid until / Gültig bis: _____ Place/Ort: _____ Date (Datum): _____ Name/Name: _____

Signature/Unterschrift: _____
 Stamp of issuing centre / Stempel der Ausgabestelle

AE FORM 55-4A, FEB 17 Previous editions are obsolete. LCD Veh. 21 30 Page 1 of 2

4.18.3. The driver of a vehicle that transports dangerous goods must be trained, as evidenced by an license with specified classes of dangerous goods that can be transported.

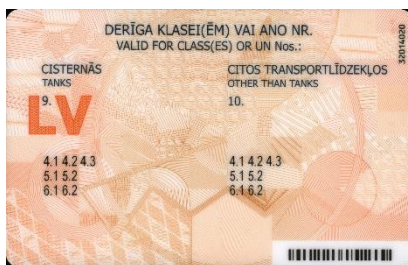

Not valid for Classes 1, 2, 3, 7, 8, 9

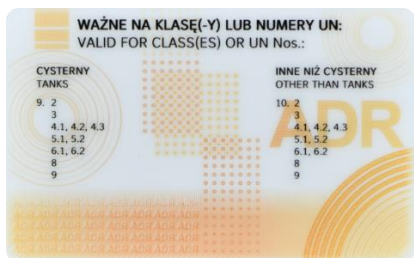

Valid for all classes, except 1 and 7

4.18.4. Before entering the terminal, the driver of the tank truck shall make sure that all valves, such as rainwater drains from overhead filling platforms, manifolds, hose boxes, etc. ARE CLOSED, to prevent potential leakage of substances that could harm the environment.



TANK TRUCK FILLING/DISCHARGE

- 4.18.5. Tank truck manifolds must be clean and dry. They cannot contain residues of petroleum products.
- 4.18.6. A vehicle transporting dangerous goods must be equipped with:
- 4.18.6.1. Valid and tested powder fire extinguishers. Their quantity must be in accordance with ADR requirements;
 - 4.18.6.2. Absorbent materials;
 - 4.18.6.3. ADR bag stacked according to ADR requirements;
 - 4.18.6.4. A full-height four (4) point harness if loading from the top is scheduled. The size of the belt should be such that it fits the driver of the vehicle.
- 4.18.7. Vehicles will not be allowed into the terminal if they have:
- 4.18.7.1. Invalid (damaged, unchecked) fire extinguishers;
 - 4.18.7.2. Petroleum products in the tank manifold that can pollute the environment;
 - 4.18.7.3. Damaged valves used to close off the flow of liquids from overhead filling platforms, manifolds, hose boxes.
- 4.18.8. All drivers involved in hazardous cargo operations (loading, unloading, offloading, and discharging) must be provided with antistatic workwear and personal protective equipment required for hazardous cargo operations, such as a valid hardhat, protective goggles, full-body (four-point) fall arrest harness, respiratory protection, chemical protective suits, etc.



LANDSCAPING AND AREA MAINTENANCE

4.19. Landscaping and area maintenance

- 4.19.1. Cutting grass with a trimmer, the employee has to make sure it has a protective shield restricting flying of different objects.
- 4.19.2. If the grass is cut in places, e.g. in front of buildings, in the immediate vicinity of carriageways, in front of buildings with windows, in vehicle parking areas, etc. in places where there is third party property damage from flying objects, the mower shall place portable "flying objects" warning signs in the work danger zone,



- 4.19.3. When cutting grass in areas where third party property may be damaged, the mower should consider all possible risks and, where possible, choose a working position that results in the trajectory of any lifted objects being away from third party property.
- 4.19.4. When cutting grass with a trimmer or raider, a powder fire extinguisher (min. size PA2) and an absorbent for unauthorised spills, e.g. when refuelling, must be present in the work area.
- 4.19.5. When mowing grass in reservoir parks, pay particular attention to the flexible hoses located in the reservoir areas, AVOID MOVING THEM AS MUCH AS POSSIBLE. If any abnormal situations are observed, e.g. hoses falling from stands, no leakage collection vessels under the connection points, leakage etc., report immediately to FRSS using available means of communication (Ex telephones, hand held reporters).



5. HOT WORKS

5.1. Types of hot works

5.1.1. Hot works includes activities such as:

- Gas welding and cutting.
- Electric welding and cutting.
- Work with open flames that involves the use of fuel.
- Work with blowtorches.
- Heating of bitumen or tar.
- Work with sparking cutting tools.
- Sand-blast cleaning of metal structures.
- Other work involving thermal effects (heating to high temperatures).



5.1.2. Hot works may only be carried out if an order to conduct hot works is prepared and all the measures specified in the order are taken. See section 3.2 for the procedure to prepare an order to conduct hot works.



HOT WORKS

- 5.1.8.5. it must be confirmed that electrical equipment is locked out (LOTO carried out);
- 5.1.8.6. the worker in charge of hot works must instruct those directly performing the work in terms of fire safety measures during the work;
- 5.1.8.7. there must be fire extinguishing equipment in the hot works area, in the amount specified in the PTW; the fire extinguishing equipment must be within 5 m from the actual work performance location;
- 5.1.8.8. the areas where the hot works takes place and the areas where welding machines and gas tanks are set up **must be** cleared of any dry grass, waste, spilled oil products and other combustible materials located within a radius of 11 m. Any areas with traces of oil products must be covered in a 5 cm layer of dry sand, soil or foam.



Any flammable or combustible materials are removed within 11 metres of the work area



- 5.1.8.9. any leaks of oil product fumes and other combustible gases must be prevented during the work;



Pipe sealed with a pneumatic sealing balloon



HOT WORKS

- 5.1.8.10. any combustible buildings, structures and openings located closer than 11 m from the open flame must be covered in a non-combustible material, and measures must be taken to prevent the occurrence of fumes, e.g. by applying a layer of sand;



***Correctly covered
production
manhole cover***

- 5.1.8.11. hot works may only be performed once a representative of the Fire, Rescue and Security Service confirms that the work order is filled in completely, and the preventive measures specified in it have been taken (by checking the work area), making an appropriate note in the work order. Once the work is completed, the work area must be presented to an FRSS representative;
- 5.1.8.12. if a break is arranged during hot works attended by on-duty FRSS officers, then once the break is over, the work may only be resumed if this is reported to the FRSS dispatch officer and the FRSS representative has checked the work area and issued their permission to resume the work;
- 5.1.8.13. if it is necessary to use a vacuum tank to perform hot works, e.g. to pump out water, then before beginning the work, one must make sure that the vacuum tank is clean and does not contain any residue of any highly flammable, flammable or combustible substances, including fumes. Only hoses intended for water may be used for pumping water;
- 5.1.8.14. if a vacuum tank is to be used to perform hot works, which must take place in a pit or a trench, the vacuum tank must be set up no closer than 10 m from the pit or trench, to prevent the ingress of harmful substances into the working environment;
- 5.1.8.15. if air quality tests in an explosive area show that there is no explosive hazard, but the presence of highly flammable and combustible liquids can be felt (smelled) in the air at the work area, one must perform additional measurements for the presence of hydrocarbons (VOC, volatile organic compounds) in the working environment. If these indicators exceed the 8 h occupational exposure value (= 26 ppm), then the hot works may not be performed until this value or a lower value is achieved;
- 5.1.8.16. if hot works is to be performed in a working environment that is harmful to breathing, then the decision to permit such work or not is issued by the project manager, in consultation with EHS specialists (e.g. prescribing specialised PPE, additional ventilation, time restrictions and other measures);
- 5.1.8.17. in an explosive area, hot works may only be performed once an air quality analysis takes place and does not reveal any concentrations constituting an explosive hazard. Furthermore, during the work, all people working in an explosive area must use personal air quality analysers and



HOT WORKS

constantly keep track of the concentration of explosive substances;



Air analyser placed in the breathing area of the worker on their clothes

- 5.1.8.18. when welding a tank, its hatches and other openings must be kept open, and the circulation of air must be maintained using a movable ventilation device;
- 5.1.8.19. it is prohibited to store any fuel closer than 11 metres from the location of hot works;
- 5.1.8.20. any welding electrode end pieces and grinding/cutting disk residue must be placed in a fire-resistant container located near the person performing the work. It is prohibited to discard any electrode residue in the work area;
- 5.1.8.21. when welding, the electrodes must be chosen appropriately for the rated welding current, and the current strength specified in WPS must be set in the welding machine;
- 5.1.8.22. in poor weather conditions (i.e. snow, rain, strong wind), outdoor hot works may only be performed in tents set up specifically for this purpose;
- 5.1.8.23. when performing electric welding, it is prohibited to use rails, grounding lines, metal structures of building utility lines and production machinery for grounding;
- 5.1.8.24. when welding, it is PROHIBITED to use electrical cables with damaged insulation;
- 5.1.8.25. when performing work on utility lines that contains oil products, the work area must be provided with absorbent products that can be used to quickly minimise any possible contamination;
- 5.1.8.26. when performing work on utility lines that contain oil products or any other substances, there must be an emergency kit at the work area containing the following objects: a special tourniquet, a patch appropriate for the diameter of the pipe;
- 5.1.8.27. if at the site of hot works, fire safety is managed by those performing the work (Contractor) through the use of a fire trailer, then it must be located in the immediate vicinity of the work area (no more than 15 m from it); its operating lines with the nozzle attached must be pulled out, and the main line must be filled and attached to the trailer (ready for operation); there must be a specially trained and equipped worker ready to react. If the outdoor temperature is 0 °C or lower, it is possible that the main line is not filled;
- 5.1.8.28. if hot works is performed in a tank with a pontoon, measures must be taken to prevent the combustible material of the pontoon (rubber seal) from igniting, for example, by protecting it with a non-combustible cover of an appropriate size;
- 5.1.8.29. in order to prevent any ignition caused by roofing falling onto the pontoon, the pontoon must be continuously monitored by people with fire-fighting equipment (fire extinguishers, fire hose



HOT WORKS

with a nozzle etc.);

- 5.1.8.30. the Contractor ensures the continuous monitoring of the work area, via a fire station with a mobile trailer with fire equipment, or a fire station with a fire extinguisher;
- 5.1.8.31. the Contractor may not begin hot works unless all the preventive measures specified in the work order to perform hot works are taken;
- 5.1.8.32. when welding, the work area must be provided with welding guards.



A portable curtain or protective wall is installed at the welding area to protect workers against exposure to ultraviolet radiation



REQUIREMENTS FOR USING GAS TANKS

5.2. Requirements for using gas tanks

5.2.1. VTL has set requirements for using, transporting and storing gas tanks.

5.2.2. Safety requirements for transporting gas tanks:

- 5.2.2.1. The valves of the tanks must be shut tightly;
- 5.2.2.2. The tanks must be transported in a trailer or in the boot of a vehicle that is separated from the passenger compartment;
- 5.2.2.3. Sufficient ventilation must be provided during transport, keeping the windows open if necessary;
- 5.2.2.4. Any accessories, such as reducing valves, hoses, torches, must be removed from gas tanks during transport;
- 5.2.2.5. The tanks must be securely attached, to prevent them from moving during transport. Gas tanks must be moved without jolts or impacts, it is not allowed to throw gas tanks;
- 5.2.2.6. It is not allowed to leave tanks in a vehicle or in other places without ventilation;
- 5.2.2.7. Once a tank is delivered to its destination, it must be immediately placed in a storage location with good ventilation;
- 5.2.2.8. It is prohibited to transport tanks with other substances that could react with the gases or are otherwise hazardous materials, such as oil and lubricants;
- 5.2.2.9. It is prohibited to transport tanks in the passenger compartment of a vehicle together with containers for liquefied flammable or oxidising gases, dry ice containers, or toxic gases;
- 5.2.2.10. When transporting gas tanks, one must avoid having passengers in the passenger compartment;
- 5.2.2.11. It is recommended to transport liquefied gas (propane, CO₂, acetylene etc.) tanks in a vertical position.

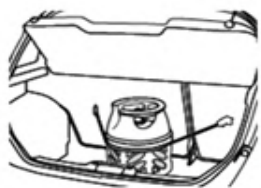

1. Tank fastened in the boot of a vehicle.



2. Do not transport unfastened tanks.

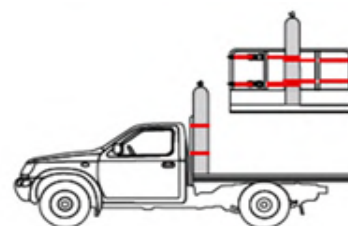

3. Tanks correctly fastened in a vertical position.

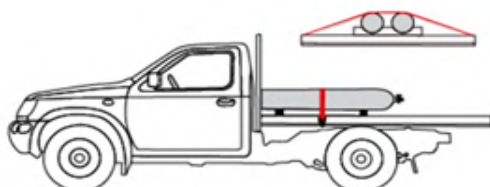

4. Tanks correctly fastened in a horizontal position. It is not recommended to transport liquefied gases in a horizontal position



5. An unfastened, incorrectly positioned tank.



REQUIREMENTS FOR USING GAS TANKS

- 5.2.3. Gas tanks intended for work must be stored in a way that does not create risks for employees, and to prevent connection points from any contact with various foreign bodies. Recommended storage method: special stands and trolleys intended for this purpose.
- 5.2.4. All pressure manometers mounted on the gas tank reducers have to be tested and verified in a certified laboratory once a year.
- 5.2.5. Empty gas tanks must be stored and transported in the same manner as tanks full of flammable gas.
- 5.2.6. When storing and using gas tanks, one must protect them from direct sunlight and sources of heat, and protect the opening of the valve from any soil entering it.



The valve of the tank has no protective cap on, as a result of which sand or soil particles can get into the valve

- 5.2.7. Gas tanks may be placed no closer than one metre (1 m) from sources of heat, and no closer than 5 m from areas where hot works is carried out.
- 5.2.8. If gas and an angle grinder are used during work at the same time, then any gas tanks, including those used for the work, must be placed at a distance of 11 m from the place where the angle grinder is used; alternatively, they must be protected against sparks with a screen.
- 5.2.9. Placing any containers for combustible liquids and flammable gases closer than 11 m from the work area.
- 5.2.10. IT IS PROHIBITED:
 - 5.2.10.1. to allow oxygen tanks, reducing valves and other gas welding and metal cutting device components to come into contact with oils, oily clothes and oily wiping materials;
 - 5.2.10.2. to obstruct hoses feeding gas by bending, twisting or squeezing them;
 - 5.2.10.3. to keep flammable or combustible liquids and other combustible materials in welding booths;
 - 5.2.10.4. to bring gas tanks into confined spaces and use them there, except for the tanks intended for breathing. Gas may only be fed from the outside of the confined space;
 - 5.2.10.5. using wire or similar methods for connecting hoses (special clamps must be used);
 - 5.2.10.6. leave tanks open, and operating hoses and reducing valves under pressure when ending work or taking breaks. During these periods, the tanks must be kept shut, and no pressure may be applied to the reducing valves.
- 5.2.11. If gas tanks intended for work are placed in open areas, they must be protected against direct sunlight and marked with safety signs for 'No smoking' and 'Do not use open flame'.



REQUIREMENTS FOR USING GAS TANKS

5.2.12. If the gas tanks are kept indoors, in (container) warehouses, there must be sufficient air circulation in the room, and the room must be marked with safety signs for 'No smoking' and 'Do not use open flame'.



The gas tank storage place is provided with indoor circulation of air, and the area is marked with safety signs



6. DOCUMENTATION

6.1. General information

- 6.1.1. Depending on the project to be worked on, the Contractor may be tasked with preparing additional documentation, in order to ensure that the work is performed in accordance with environmental, occupational safety, fire safety and explosion safety requirements.
- 6.1.2. A *work execution plan (WEP)* is an integral part of contracts for permanent construction projects, maintenance projects and environmental protection projects.
- 6.1.3. The choice of which of the documents (WEP or WRA) the Contractor is to prepare is determined by the project manager appointed by VTL, stating it in the technical specifications or in the contract.
- 6.1.4. The Contractor must prepare the WEP and have it approved by VTL persons in charge before the work order is prepared.
- 6.1.5. As an exception, WEP may be replaced with the work risk analysis (WRA) document. Replacing WEP with WRA requires written (e-mail) approval of the EHS manager, the technical manager, the production director and the safety coordinator.

6.2. 'Work execution plan' (WEP)

- 6.2.1. **The work execution plan** must be prepared in accordance with the **VTL-16.FM.010** 'Guidelines for the preparation of a work execution plan'.
- 6.2.2. Work execution plans must be submitted for review by the VTL person in charge of the plans in digital form; this person in charge will then forward the plans to the other VTL representatives responsible for the matter.
- 6.2.3. Work execution plans must be submitted at least 5 business days prior to the day, on which the work is to begin.
- 6.2.4. Work execution plans are reviewed, approved or provided with comments on necessary corrections within 4 business days.
- 6.2.5. The Contractor prepares 2 paper copies of the approved work execution plan and coordinates this with the responsible VTL representatives.
- 6.2.6. The work execution plan must be approved by the following persons responsible at VTL:
 - Head of the VTL Technical Division;
 - Head of the VTL Operations Division;
 - Head of HSEQ Division;
 - Environmental and Safety Engineer;
 - Labour Protection Specialist;
 - Process Safety Engineer;
 - VTL Project Manager in charge.



- 6.2.7. During the initial stage of permanent construction projects, VTL provides the Contractor with contact details of the persons in charge during the period intended for the preparation of the project in question. The Contractor includes the information received in the work execution plan.
- 6.2.8. Storage and use of materials. If the specifications of the engineering design allow the Contractor to choose certain materials and devices, then VTL must review and approve the materials and equipment to be purchased by the Contractor prior to their purchase. Otherwise, the Contractor must strictly comply with the regulations specified for the equipment and take responsibility for any deficiency that it will have to eliminate at its own expense.



ENVIRONMENTAL PROTECTION, WASTE MANAGEMENT

7. ENVIRONMENTAL PROTECTION

7.1. General requirements

- 7.1.1. The Contractor adopts all necessary precautions to prevent pollution of the environment or its risk, or the risk of emergencies, or minimise these if prevention is impossible.
- 7.1.2. If during work, there is a possibility of soil and/or ground water pollution with oil products or other hazardous substances, then before the work takes place, all measures must be taken to prevent such pollution, or to minimise any spills into the soil, the air and into water. Work areas and vehicles must be provided with an appropriate absorbent material and/or other, at least equivalent, measures necessary to quickly limit the spread of pollution with hazardous chemicals or other products, and to eliminate such pollution.

7.2. Waste management

- 7.2.1. The Contractor prevents or, if prevention is impossible, minimises the occurrence of waste, and ensures the correct management of waste in accordance with the procedure set by VTL: hazardous waste must be sorted and discarded separately, to avoid the mixing of different types of hazardous waste.



Waste contaminated with oil products discarded along with household waste

- 7.2.2. The Contractor must submit a waste and wastewater management plan that must be approved by the VTL, if this is required by the VTL project manager.
- 7.2.3. The Contractor is fully responsible for transporting all construction waste and construction materials, such as metal scrap, insulation waste, rubble, industrial waste and other types of waste, off the site.
- 7.2.4. When bringing natural resources, such as soil, subsoil, sand, into and out of the VTL territory and which are used to carry out the work, the Contractor shall provide the Project Manager and the Health, Safety, Environmental and quality Division with documentary evidence of the origin of the resources, such as a material declaration, as well as of the further use or waste management, such as waybills and deeds upon export.
- 7.2.5. The waste and construction waste management process (sorting, records, storage, disposal) must comply with the requirements of Latvian laws. The construction waste being prepared for transportation must be stored in the place intended for it; the place must be provided with a fence or barriers to ensure proper safety.
- 7.2.6. The Contractor is responsible for disposing of hazardous waste (e.g. discarded batteries, materials contaminated with oil products).
- 7.2.7. When pumping out ground water (to lower the water table), the machinery performing the task must be kept in adequate technical condition, preventing any water spills and leaks. **The water must be**



ENVIRONMENTAL PROTECTION, WASTE MANAGEMENT

pumped into the specified area/well.

7.2.8. Requirements for managing hazardous waste:

- 7.2.8.1. it is prohibited to mix hazardous waste that belongs to different categories of hazardous waste; it is also prohibited to mix hazardous waste with household waste. If such mixing of hazardous waste occurs, the party that created, owns or manages the waste must separate the waste. If separating the waste is impossible, this is reported to the VTL person in charge (the project manager);
- 7.2.8.2. every packaging of hazardous waste must be marked in accordance with the effective regulations that determine how to keep records of hazardous waste, how to identify it, package it, label it and transport it;
- 7.2.8.3. the collection of oil, oil product and other hazardous material or mixture spills must be carried out in accordance with the environmental protection requirements specified on the safety data sheets. The waste produced as part of collecting a spill must be managed in accordance with Section 7.3.7.2;
- 7.2.8.4. the waste must be transferred to a waste management company that has a permit for managing the hazardous waste of the kind in question.
- 7.2.8.5. it is STRICTLY PROHIBITED to dispose of cigarette butts in clear waste containers and containers for paper, plastic. CIGARETTE BUTTS MUST BE DISPOSED OF IN A MUNICIPAL WASTE CONTAINER.
- 7.2.8.6. Records of hazardous waste must be kept, and data pertaining to it must be logged in accordance with applicable law.
- 7.2.8.7. Adhere to the requirements for the recording of non-hazardous construction waste.
- 7.2.8.8. Records must be kept of any construction waste that is not hazardous; also, when transporting construction waste, a construction waste transport registration statement (bill of material) must be prepared, in accordance with the effective regulations.
- 7.2.8.9. It must be ensured that waste is transported away regularly, not allowing it to accumulate outside waste containers.



Waste discarded outside a waste container



ENVIRONMENTAL PROTECTION, WASTE MANAGEMENT

7.3. Protecting greenery

- 7.3.1. Greenery can be defined as any and all areas covered in plants that are cared for. Greenery can include trees, bushes, climbing plants, flowers, lawns, roads, bodies of water, paths, areas with garden furniture and equipment, gardening structures etc.
- 7.3.2. All greenery areas on the premises of VTL must be protected.
- 7.3.3. When performing work on the premises of VTL, the Contractor must take the following protective measures if the work it performs can result in damage to trees:
 - 7.3.3.1. Fence off the tree trunks in the work area using screens that are at least 2 metres tall.
 - 7.3.3.2. Horizontal guards must be installed around the trunk of the tree to protect its roots if necessary.
- 7.3.4. If the root system of a tree is affected as part of setting up and repairing utility lines, the necessary protection measures must be coordinated with the VTL environmental protection specialist.
- 7.3.5. When performing construction, prevention of changes to the ground level in greenery areas by more than 0.05 m compared to the current level must be ensured. If the ground level is to be raised or lowered, the construction design must include special measures that ensure that the trees can grow. When digging under a root system, this must be done at a depth of no less than 1.5 m from ground level, without damaging the roots.
- 7.3.6. Construction and other materials (fuel, lubricants etc.) must not be less than 10 metres away from trees or bushes.
- 7.3.7. Any access routes for construction sites must be set up without encroaching on any greenery and without removing any screens to protect the trunks of trees.
- 7.3.8. VTL is entitled to charge the Contractor compensation for any unauthorised felling or damaging of trees resulting in the tree becoming partially or fully unable to grow.



HOW TO ACT IN AN EMERGENCY AND DURING EVACUATION DRILLS

8. EMERGENCIES

8.1. How to act in an emergency and during evacuation drills

- 8.1.1. **In the event of any emergency** (oil product spills, leaks, fires, accidents etc.), the Contractor's employees must report it to the VTL Operations Division, by calling **6366 6300** or pressing the nearest **manual alarm button**.



- 8.1.2. Course of action in situations when a fire alarm sounds in the building:
- 8.1.2.1. workers must immediately leave the building and go to a safe location (if a safe assembly point is too far), e.g. the other side of a road, making sure not to obstruct the emergency services, unless the VTL voice alert system instructs them to perform specific actions;
 - 8.1.2.2. always close the doors when leaving rooms (or the building);
 - 8.1.2.3. when evacuating, always take your documents and other important things with you. Also outerwear if the weather is cold;
 - 8.1.2.4. returning to the building is only allowed if it has been inspected by FRSS officers who gave their permission to return.
- 8.1.3. The Contractor must report any accidents and injuries that occur to the Contractor's employees on the premises of VTL to the VTL occupational safety specialist by calling 6366 6253, or to the Contractor's immediate supervisor. Any method or equipment for providing information may be used to report the accident, provided it is the fastest way to provide the information. The place of the accident must be left as untouched as possible.
- 8.1.4. If the life of a victim is in danger, first aid must be immediately administered to them in accordance with occupational safety rules. Emergency medical aid may only be administered by the staff specially trained to do so.
- 8.1.5. First aid may be received at the Fire, Rescue and Security Service of the VTL terminal.
- 8.1.6. In order to confirm that the victim has not breached the Vitol Terminal Latvia regulations and procedures pertaining to the prohibition of alcohol and narcotics on the premises of the Terminal, the victim may be administered a breath alcohol test using the breath alcohol tester available at the Terminal and a test for the presence of narcotics in the victim's saliva using the testing equipment available at the Terminal immediately after the victim receives first aid. If necessary, the victim is sent for a medical examination to detect the influence of alcohol, narcotics, toxic or psychotropic substances, following the procedure specified in the laws and regulations governing testing the influence of alcohol, narcotics, toxic or psychotropic substances.



HOW TO ACT IN AN EMERGENCY AND DURING EVACUATION DRILLS

- 8.1.7. When hearing a notification via the voice announcement system, the Contractor's employee must listen to it and act in accordance with the instructions stated in the notification. During evacuation, including during drills, the Contractor's employee (employees) must go to the nearest safe assembly point, picking up an escape hood on the way, and signing off using their entry pass at the assembly point.
- 8.1.8. If an employee of the Contractor does not understand the notification, they must assume that it is an alarm signal, and they must act as specified in Paragraph 8.1.7.



HOW TO ACT IN AN EMERGENCY AND DURING EVACUATION DRILLS

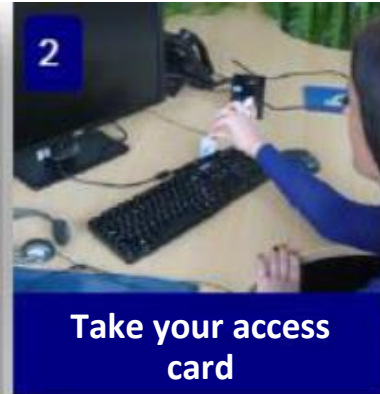
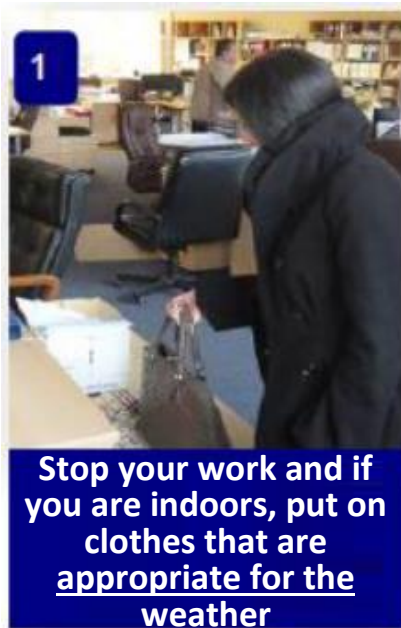



USING AN ESCAPE HOOD



8.2. Using a Dräger PARAT 7530 escape hood

8.2.1. The hood is a single-use item. The hood may be used for no longer than 15 minutes. Beyond that, the hood will lose its seal and stop functioning properly.

Put the hood on at the time when it is necessary: it starts working as soon you open the packaging!

8.2.2. The escape hood offers protection against the following gases:

- 8.2.2.1. A1 — organic gases and fumes, including solvents;
- 8.2.2.2. B1 — inorganic gases and fumes, including chlorides, hydrogen cyanide fumes, hydrogen sulphides;
- 8.2.2.3. E1 — fumes and gases of acids;
- 8.2.2.4. K1 — ammonia;
- 8.2.2.5. CO — carbon monoxide;
- 8.2.2.6. P3 — any types of hard and liquid particles.



USING AN ESCAPE HOOD

8.2.3. Putting the hood on:

Step 1: take the hood from the location or cabinet where it is stored



Step 2: open the PVC packaging of the hood by unlocking the yellow latch, and take the hood out of its packaging



Step 3: unfold and spread the hood so that you can see the breathing device through the opening in it and start putting the hood on starting with the top or the bottom of your head. Put the hood on and adjust the breathing device.





8.3. First aid

- 8.3.1. Near the work site, the Contractor must provide an operational first aid kit with dressing materials and other first aid products necessary based on the risks specific to the work performed by the Contractor, e.g. burn sprays, eye rinsing products etc. The responsible Contractor must keep the first aid kit fully equipped, and ensure that any medications in it are not expired.



- 8.3.2. If a fall occurs during work, and the workers of the contractor have lifted the victim up prior to the arrival of FRSS, the victim must be put in a sitting position, with the knees bent at a 90-degree angle, for at least 20 minutes, and only then laid down.

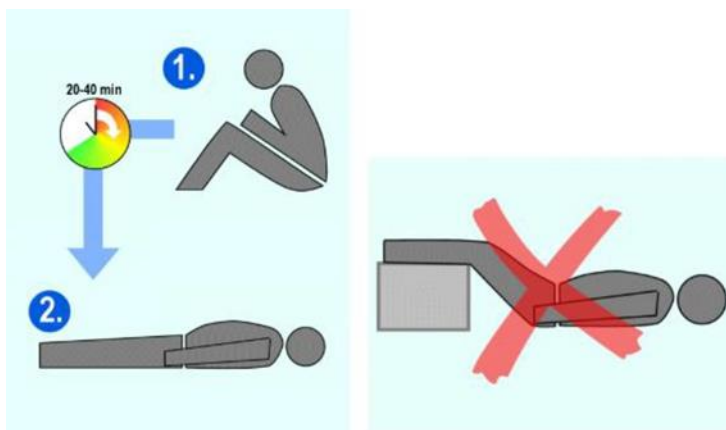



8.3.3. Emergency showers and stations with products for rinsing eyes are provided for situations when oil products are accidentally spilled onto an employee of the Contractor.

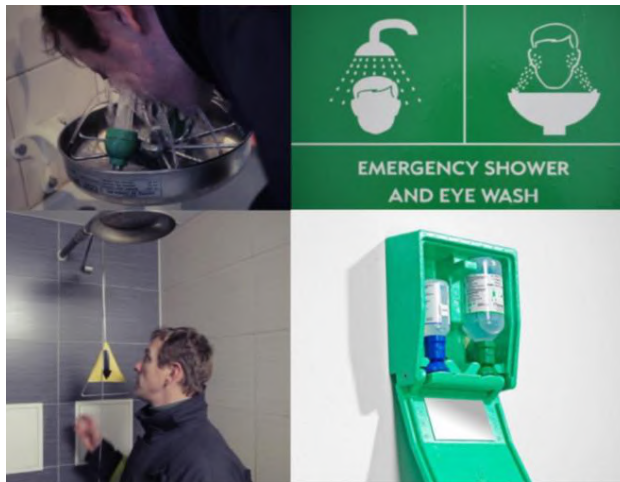

The locations of the emergency showers are shown on the map of VTL premises, which one receives when entering the premises



CONTACT DETAILS OF PERSONS IN CHARGE

9. CONTACT DETAILS OF PERSONS IN CHARGE

The contact details of persons in charge are provided to the Contractor once the contract is signed.